

Discovering Universal Reality

Paramahansa Tewari

2007

Editions India

C O N T E N T S

Preface

INTRODUCTION

1. **Motion Pervades the Universe**
2. **Newtonian Physics of Void-Space and Solid-Matter**
3. **Force-Fields Demolished Newtonian Void-Space**
4. **Structural Relationship between Space and Matter**
5. **Universal Gravitation**
6. **Space Inherent with Circulating Motion**
7. **Electrical Repulsive Forces between Cosmic Bodies**
8. **Derivation of Mass of Cosmic Bodies**
9. **Orbital Stability and Mass of Planets**
10. **On Motion of the Electron**
11. **On light –Additional Facts**
12. **Universal Constants**
13. **Creation of Cosmic Matter**

CONCLUSION

Appendix

To the seekers of truth.

To those who truly think freely, unencumbered by their times.

On whom lies the onus to steer Science to its rightful destiny of universal truth.

Through the theories that have clarity, and are distinct and comprehensive.

Which discriminate between the transient and the eternal, the real and the false.

And thus, reach, finally, the One entity that constitutes us all.

P R E F A C E

All truths are easy to understand once they are discovered;
The point is to discover them.

Galileo

I first conceptualised the principles of my Space Vortex Theory (SVT) in the mid 1970's, and hypothesised them in my books to follow. This work is an exposition on the Principles of SVT.

The primary role of physics and its scientific enquiry is arguably to speculate, conceive, theorize, experiment and discover the most fundamental elements in both, the structure of matter in the universe, as well as in the seemingly limitless expanse of space. Also, the structural relationship between the fields and the space in which they exist and are transmitted needs to be discovered.

It would seem that the 20th Century theories failed to keep pace with experimental findings, and deviated from the ongoing trend of picturisation of, and detailed physical explanation to, phenomena, such as those pertaining to nuclear and atomic structure, nature of light. Had it been otherwise, the fundamental particle of matter would have been identified, latest, by the middle of the 20th Century. That, however, has not happened.

Research on the interrelationship between the force-fields and space have been largely neglected in the 20th Century's Physics Establishment, presumably, under the impression that Space without fields is a mere void-ness. This can be shown to be a mistaken notion. Though force fields have been accepted as the most fundamental energy-entities, yet their creational process has been left in obscurity. It is equally important to determine the location and the originating process of cosmic energy, creation of matter of the universe, as well as the source of universal motion as seen in the movement and rotation of cosmic bodies, atomic vibrations, particle's rotation (spin).

The depth of the Universe is today understood to be the distance from us to the farthest galaxy, stars, or any other cosmic matter, because these are presently supposed to move in a void-ness, called Space. But if the universal Space is inferred through the phenomena already observed as a subtle fluid, then it will be pertinent to ask whether a vast sphere of this subtle fluid has a finite volume, or is in fact, infinite.

Current astrophysics, Relativity, and Quantum physics of atoms and sub-atomic particles have yet to go deeper into the structure of matter, where answers to the above issues can be found. For instance, in nuclear structure, in addition to the forces of attraction and repulsion caused by electric and magnetic fields, there are hidden nuclear forces arising from Space rotation and its reaction, that have so far not been discovered in contemporary theories. Thus, nuclear theories currently analyse nuclear stability with forces lesser than what exist in reality. They are forced to postulate very strange forces,

while taking shield behind an often declared policy that classical approach in quantum physics is unworkable.

In addition to matter, when spatial reality is taken into account, the unexplained phenomena in physics, both of micro and macro Cosmos, get to be explained fully. The universe of vast Space will then be seen as a real volume of cosmic energy, eternal in existence, and eternal in its laws.

I am grateful to my son Anupam, and my friends and colleagues Toby Groz and James Sheppard for their editing and suggestions during the writing of this book.

Paramahansa Tewari

INTRODUCTION

This work considers the fundamentals of matter. The theory expounded here discovers one fundamental particle that structures all other elementary particles, including atoms. All matter is shown to be created from only one basic entity – fluid-space in dynamic condition. Also, there is only one universal constant that derives all other constants that are presently known in contemporary physics.

A new approach has been adopted in deriving the properties of matter from First Principles. Postulates have been made on a universal entity that does not possess any material properties – so that the very origin and the processes of creation of these properties can be discovered.

All matter, characteristically, has mass, but why does matter possess mass? Why, too, does an electron, the “unit of electrical charge”, show mass property? Speculating on electron structure became an obsession with me, as a research hobby, right after my graduation with a Bachelor’s Degree in electrical engineering in the late 1950’s, and even more seriously since the early seventies 1970’s.

It is a known fact that motion of electrons in a current carrying conductor produces circular magnetic field around it. Also, the magnetic field lines are directional. This provided a clue that the electrons themselves may have some kind of rotating structure. And the magnetic field lines may not be a mere convenient representation of magnetic effect. Instead, the circular and directional field lines may be either indicative of a real flow or acceleration of fluid-space (hereafter termed as ‘space’, unless an emphasis on fluidity of Space is required), or a pressure condition in space. The question then arose as to what properties needed to be postulated for Space. If the electron is postulated to be a space-vortex, then, in order to account for its mass, space has to be, logically, assigned with density (mass/ volume), howsoever small. Such a system of enquiry would mean that space, already possessing mass-property, creates the electron that has mass. But, this fact is of no consequence to being able to trace the basic source of mass, right at its origin. Here, then, was a Gordian knot that needed to be cut somehow if the genesis of mass was to be unearthed. With a passionate effort to search for the most fundamental state of space, and with an intuitive insight that matter has to be created from space alone, it occurred to me that unless a mass-less entity is postulated as the basic substratum of the universe, the process of creation of mass in matter would continue to remain obscure. A new problem arose. Can a mass-less space produce matter having mass property, especially because mass has been recognized as energy itself from the mass-energy equation? This almost brought about almost a dead end to my further speculative investigation (1972).

The solution came by postulating a limiting velocity-gradient at which the flow of space, when in vortex circulation, breaks down, thus creating another medium –a void (vacuum-less, space-less, volume of nothingness) located at the vortex center. The mass property of electron was attributed by me to the existence of this very volume of void –a new concept, unheard of in earlier theories of electron structure –but it worked successfully, solving the unresolved issues related to properties of electron and its behavior, and matter in general.

With the spherical void at electron center, enclosed within a mass less space vortex – the vortex filling the whole universe – the universal space, accepted by contemporary physics as “emptiness”, got filled with a unique kind of fluid, while the electron-center became empty. The Newtonian universe of empty-space and solid atoms was turned upside down, and yet the basic equations of mechanics and gravitation by Newton, and also by Coulomb, Gauss, Ampere, Planck and Einstein (mass energy equation) were accurately derived from the vortex structure of electron (discussed later in detail). Similar to the space-vortex structure of the electron, other entities were shown to possess space vortices enclosing them, namely proton and atoms, as well as planets, stars and galactic cores.

The way in which an atom with space-vortex structure contrasts with the model of the atom as per the quantum theory is evident in the following quotation from the article¹ by Darrow. “A hydrogen atom with its electron revolving in a circular orbit about its nucleus can be regarded as a wheel. It is a peculiar kind of wheel, since it has no spokes and the rim is vacant except for the small region occupied by the electron, but it possesses the major property of a wheel: angular momentum.” Darrow points out that the space around the nucleus is “vacant”, whereas, the small region occupied by the orbiting electron is not vacant. However, just the reverse is the case in the atom of hydrogen with a space vortex structure, in which the center of the electron is vacant, whereas the region around the nucleus is fluid-space. The space vortex enclosing the nucleus imparts angular moment to the orbital electron.

New basic equations on electron mass and charge were theoretically formulated from the space vortex structure of electron. The mass and charge of electron, derived from these basic equations, were compared with the experimentally obtained values to have confirmatory proof of the fundamental equations. Further, these equations are shown to be applicable for macro-cosmic bodies as well for the derivation of their mass and electric charge.

Certain basic phenomena in quantum physics –wave-particle duality, matter waves, absorption and emission of photons by electrons, indeterminism, and abolition of clear-cut trajectory –are shown to be the result of the prevailing misconceptions on the basic nature of Space, true structure of light, electron, nuclear and of atomic structure.

It is discovered that the planets in the solar system electrically repel due to the space-vortices enclosing them. Electrical forces also cause attractive and repulsive forces between galaxies –a new revelation –hitherto not discovered.

Einstein is vindicated for his discovery of light speed being the maximum speed of matter in the universe, and also for the mass-energy equation. In Chapter 4 it will be seen that a more basic and generalized postulate on light-speed, being the limiting value,

¹ The Quantum Theory, Karl K Darrow, Scientific American, March 1952, Vol. 186, No. 3, 47-54)

has been taken by postulating that the flow of space itself breaks down at speeds beyond the speed of light (with respect to space.) However, time dilation in special relativity and explanation of the photoelectric effect are shown clearly to be erroneous concepts when the true nature of light, discussed in this work, is taken into account.

The cosmic energy that accounts for the creation of matter in the universe is identified as *dynamic space* –“fluid space in acceleration” –which is the definition of the most basic energy in this work.

Modern theories of subatomic particles, without full physical details, might as well have their roots in misconceived ideas and the misinterpretation of experimental results –the latter being more likely. Erwin Shrodinger, famous for ‘Shrodinger equation’ in quantum mechanics (1926) writes¹, “We have to admit that our conception of material reality today is more wavering and uncertain than it has been for a long time. We know a great many interesting details, learn new ones every week. But to construct a clear, easily comprehensible picture on which all physicists will agree –that is simply impossible. Physics stands at a great crisis of ideas.”...We hope that the present fluctuations of thinking are only indications of an upheaval of old beliefs which in the end will lead to something better than the mess of formulae which today surrounds our subject”. Schrodinger’s wave mechanics, starting with Louis de Broglie’s suggestion on wave/particle duality, was so presented that in the hydrogen atom ‘the electron is not to be considered as encircling the nucleus in a circular orbit, but instead it is spread out in a way that is totally unpicturable classically’. Thus, within a short span of fifteen years, Rutherford’s great discovery of atomic structure was eclipsed with the theories of Schrodinger, Heisenberg, Paul Dirac and Max Born, admittedly under razing competition for framing theories, because the duration is too short for engaging serious thoughts on intricate and subtle phenomena associated with atomic structure.

Physical theories in the early 20th Century digressed from the direct path to scientific knowledge under several constraints. This work pinpoints the stages and the reasons for the digression. It also provides solutions through the alternate principles of the space vortex theory.

¹ What is Matter? Scientific American, September 1953, Vol.189, No. 3, pp.52-57

Chapter 1

MOTION PERVADES THE UNIVERSE

It was Rene Descartes, the French Mathematician and Philosopher, who, perhaps for the first time in a *broad scientific* sense, assigned a reality to the medium of space as a *property-less* fluid-entity, already known at that time as ether. According to Descartes' Vortex Theory, large cosmic ether vortices existed throughout the universe. One such vortex carried the planets around the sun, and countless smaller vortices aggregated into different sizes of universal matter filling the whole of space. He explained gravity by the pressure and impact of ether on bodies; Framed the principles of the inertial tendencies of matter for straight line motion based on the property of the fluidity of a space-substratum filled with ether vortices. The transmission of the magnetic forces already known at the time was explained by the force of gravity between the earth and the planetary bodies in Cartesian philosophy -- which posited that *physical contacts* between the interacting entities was exercised through the intervening ether. The theory of Descartes was the most convincing natural philosophy at/of the time and was based on a single entity of *dynamic ether* as the only reality of the universe. His own confidence in the correctness of his theory was so great that he proclaimed "Give me matter and motion and I will construct the universe".

Descartes is the author, too, of *Cogito, ergo sum*, meaning; I think, therefore I am. This¹ suggests that the consciousness of the thinker is integral to his intellect and the process of thinking. And, so, if a phenomenon in nature/ of nature (whatever nature's phenomenon) is grasped crystally clear upon deep thinking and meditation, it must necessarily be true. He also believed that investigation of experimental results would lead to knowledge. Experience, experience, and once again experience, was his exhortation. No doubt, he made the most original contributions to science and mathematics-----a new scientific method, questioning nature mathematically and use of deductive logic He conceived Cartesian geometry, thus unifying geometry and algebra together and framed the above mentioned Vortex Theory as well as his discoveries in optics. Descartes works remained in acceptance for almost a century after publication of Newton's Principia. The extent to which Cartesian cosmic vortices were of use to explain motion in the solar system can be understood by after going through the discoveries of Copernicus and Kepler as follows.

Nicholas Copernicus (1473 – 1545), Professor of Mathematics and a devout monk deeply studied planetary motions, compiled their tables and hypothesized and proved that the solar system is centered on the Sun rather than the Earth (as per the then prevalent Ptolemaic system.)

Tycho Brahe (1546-1601), the founder of instrumental Astronomy, made accurate astronomical observations that helped Johannes Kepler (1571-1643), a mathematician gifted with penetrating speculative ability and thinking power, to discover elliptical orbits of the planets, connection between their speeds in orbits and their distances from the Sun.

¹ The Scientific Work of Rene Descartes, By J. F. Scott

Kepler's laws of planetary motion are: (1) Planets describe ellipses, with the Sun in one focus. (2) The line from the Sun to any planet describes equal areas in equal times. (3) The squares of the periodic times of the planets are proportional to the cubes of their mean distances from the Sun.

Kepler also pondered over the cause of orbital motion and postulated that a force (perhaps, the then known magnetic force) emanating from the Sun propelled the planets in their orbits. Descartes' cosmic vortices provided the agency to propel the planets in the solar space vortex in elliptical orbits. Leibniz proved that planets are moved in their orbits by their ethers.

The geocentric solar system posited had a stationary earth, but in heliocentric system the Earth with its oceans, rivers and mountains, structures and forests has to travel at nearly 30 km/s around the Sun as well as rotate around its axis at nearly half a kilometer a second! Despite these tremendous motions in space its surface has to be motionless in relative terms. Thus, a great conceptual shift was required to accept Copernican discovery.

Galileo, the experimental Natural Philosopher's experiments on freely falling bodies and observance of motion of bodies on inclined planes, laid the foundation to laws of motion in mechanics. As per him the book of Nature was written mathematically. "Galileo believed¹ in a law of circular inertia and regarded as implausible the Law of Linear Inertia.... He also "asserted that bodies move naturally, because of some intrinsic property which they possess and not because they are caused to move by some external agent or mover. At that time, it was a belief that science ought to explain every change of motion. However, Galileo held that certain motions with constant velocity are natural, that they are not caused by external agents, and only accelerating motion need to be explained by science. Applying this principle to planetary motion, unlike Descartes, Galileo will not postulate an underlying solar vortex for orbital rotation of the planets, and neither did Newton. It is thus seen that the great Galileo² – founder of basic principles of mechanics, inventor of the telescope, microscope and discoverer of Jupiter's satellites, new stars and nebulae – proposed, in a sense, some limitation to deeper scientific enquiries in accepting uniform motion of bodies without investigating its cause.

Galileo defended the Copernican system, and was formally cautioned to withhold teaching of the same. On the other hand, Descartes³ "formally denied that the Earth moved, and only asserted that it was carried along (with its waters and air) in one of those larger motions of the celestial ether which produce the diurnal and annual revolutions of the solar system".

These subtle explanations of interrelationship of diurnal motion of the earth with the surrounding space are forgotten facts in contemporary physics. In my other works, I have established structural relationship between matter (electron, atom, cosmic bodies) and space (absolute vacuum), with which Descartes' above explanation has been analysed later.

¹ Issac Newton's Principia, Alexandre Koyre & I. Bernard Cohen

² Sir Oliver Lodge, Pioneers of Science (1926)

³ Sir Oliver Lodge, Pioneers of Science (1926).

Chapter 2

NEWTONIAN-PHYSICS OF VOID-SPACE AND SOLID-MATTER

Sir Isaac Newton (1642-1727), believed in voidness of space and solidity of atoms. This was quite similar to Leucippus' and Democritus' (Greek Philosophers) conception nearly 2500 years ago, of "Atoms and void", to be the basic constituent of the universe.

Galileo's noteworthy experiments on freely falling bodies and motion on inclined planes provided Newton with further insight to frame the Laws of Motion¹:

Law 1: Every body continues in its state if rest, or of uniform motion in a right line, unless it is compelled to change that state by forces impressed upon it.

This Law 1 is certainly close to the following Laws from Descartes², postulated earlier than Newton's:

The First Law of Nature: that each thing as far as in it lies, continues always in the same state; that this state changes only by collision with other things.

The Second Law of nature: that all motion is of itself in straight line; and thus things that move in a circle always tend to recede from the center of the circle which they describe.

In Cartesian fluid space a finite body is constituted of a compact assembly of tiny vortices and immersed in universal ether. When it is moved from rest, it would further continue to move in a straight line by the action of the surrounding fluid, if postulated to be a non viscous fluid. This is the genesis of momentum as discussed further. It gets evident that the inertial property –straight line motion of bodies, as conceived by Descartes, requires a fluid substratum. Strange as it seems, Newton chose not to take into account any interaction with the fluid substratum. And yet he framed his Law 1 with an axiom almost the same as Descartes' laws. The very spatial entity that combined with matter causes inertia (Descartes) is ignored by Newton, thus laying foundation for a new physics of void-space that could not provide a complete physical picture to many basic phenomena in mechanics.

"It³ is now becoming generally known that the word 'inertia' introduced into science in its modern technical sense by Newton, was first used in a physical context by Kepler...Kepler used 'inertia' in its original and literal sense of 'laziness'. This implied in the older pre-Galilean-Cartesian-Newtonian physics, that a force is always required to maintain motion, that –owing to the inherent 'laziness' of matter –a body will come to rest whenever the *vis motrix* ceases to act".

¹ The Changeless Order, The physics of Space , Time and Motion, Arnold Kosolow, 1967

² Same as above

³ Isaac Newton's Principia , Alexandre Koyre & I. Bernard Cohen

“Newton does not mention Kepler’s name in discussing inertia in any of the printed editions of Principia....Newton introduces inertia in ‘Definitio 111and ‘Lex Motus1’without any reference to Kepler, or for that matter Descartes, to whom he certainly was indebted for the law of Inertia”.

In Newtonian mechanics, there was no use of ether as a way to explain the properties of mass and inertia – except that these properties were attributed to certain innate properties of atoms. Thus the medium of space, except for its utility as a continuous fluid-substratum for the transmission of light waves, was again made inert and inactive for transmission of forces. And this led to the re-introduction of the principle of “action at a distance”. Based on this principle, R. G. Boscovich (1711-87) tried to explain all physical effects, as well as Coulomb and Ampere, who followed it in explaining the mutual action of forces between charged bodies and electric currents.

Having rejected spatial ether, Newton believed¹ that ‘a certain most subtle Spirit which pervades and lies hid in all gross bodies’ causes different phenomena like mutual attraction of atoms, coherence, attraction and repulsion, and possibly mass and gravity. However, the most significant contribution to the laws of mechanics come from Newton’s second law of motion (Force = mass x acceleration) where Mass was used for the first time in an equation. Though the genesis of Mass is not known even today, and it was too early in the development of science for one to know it then, this equation along with Huygens centrifugal force has led to some basic principles and computations of forces in engineering systems. Similarly, a change of momentum produces force as per the second law, and is of immense use in engineering calculations. But the origin of momentum in a body moving in a void-space is the least understood phenomenon, in a physical sense.

Newton is not unambiguous in his definition of space. On the role of space in creation of matter, and its mobility, his statement² is clear. “Absolute space, in its own nature, without relation to anything external, remains always similar and immovable”. With this it is clear that space, unlike Cartesian space, is neither dynamic nor creative.

In 1673 Huygens, published that a body in uniform circular motion is subjected to an outward acceleration (creating centrifugal force), which is directly proportional to the square of the speed, and inversely to the radius of rotation. Newton used the inverse of this force, coining a new word, centripetal force, as the central force to keep a planet in its orbit. But there are some obscurities in Newton’s work in assigning only the central force and neglecting a tangential action to keep a planet going in its orbit. “Descartes, and after him Gassendi, had written³ that such continued motion (i.e. planetary motion) without an external force...can only be linear”.... Hence, it was conceived that, in circular (or any curvilinear) motion, there must be a combination of a linear (tangential) or inertial component and a central or an accelerated component –an impressed force and an accelerating force. But Newton seems to have ignored the tangential force on the planets. Because, where was any other real entity in the void-space surrounding the planets to generate such a force?

As a result, while Newton – using Cartesian geometry and calculus, could prove that the planets moved in elliptical paths, yet he could not prove as to why only an elliptical path is taken by the planets. Because⁴ “under the action of an inverse-square force , an object will not necessarily move along an ellipse , but its path will be either a straight line directed towards the center of the force, or a curve that may be a circle, a parabola, an ellipse, or even an hyperbola”. In this way, Descartes’ explanation of gravitational force caused by the surrounding ethereal space on the Earth (as well as on other planets) as an inward pressure was in due course replaced by the above central force acting on the principle of “action-at-a-distance”in empty space.

¹ Issac Newton’s Principia, Alexandre Koyre & I. Bernard Kohen

² The Changeless Order, Theysics of Space, Time and Motion, Arnold Koslow

³ Issac Newton’s principia, Alexandre Coyre & I. Bernard Cohen

⁴ Issac Newton’ Principia, Alexandre Koyre & I. Bernard Cohn

Chapter 3

FORCE-FIELDS IN SPACE DEMOLISHED NEWTONIAN VOID SPACE

3.0 Faraday's Force Fields

The ethereal space concept continued to enable transmission of the light-effect, while on the very nature of light there were different views, mainly from Descartes, Hooke, Newton, Fermat, and Huygens. For instance, as per Descartes light effect is a statical pressure in ether, while Hooke saw it as ether's vibratory motion. Newton and Laplace believed in corpuscular model—a light source emitting corpuscles of light. However, Thomas Young and Augustin Fresnel finally proved (supported by the experiments of G.B. Airy, Foucault and Fizeau) that light-effect is wave-like in fluid ether.

Further, Faraday's experimental researches led him to the conclusion that the effect of electromagnetic induction cannot take place without the intervening medium's influence (field). Faraday introduced the concept of continuously varying electric and magnetic fields, signifying that space is a continuous substratum, with "action at a distance" not being the basic principle. Also, he suggested that an atom might be a structure of fields of forces – electric, magnetic, and gravitational, existing around its central point. On the existence of ether, Faraday believed that it may have its utility in other physical effects, in addition to providing a medium for transmission of light. Based on the Faraday's concepts, Maxwell wrote equations using hydrodynamics to model ether, postulating that it was like an incompressible fluid. Helmholtz conceived the ether vortex filament as electric current. W. Thomson believed¹ that 'the magnetic energy is the kinetic energy of a medium occupying the whole space, and that electric energy is the energy of strain of the same medium.' Atomic structure as a vortex motion was also conceived by Thomson and others, and after the electron's discovery (1897), Larmor concluded that the electron is a structure in the ether, and that all matter consisted of electrons only.

Serious problems arose (1905) with the concepts of the vortex structure of atoms / electrons in an incompressible fluid. One problem was that of the dissipation of vortex motion, since the streamlines in a vortex may tend to dilate outward (W. Thomson). Another problem pertained to the difficulty of the transmission of an electromagnetic field in this fluid at the enormous speed of light, unknown in material media. For, if light is considered similar to a mechanical disturbance in a material medium, then, for ether, the quantity: $(\text{elasticity} / \text{density})^{1/2}$, which is proportional to the speed of the disturbance, must have a very high value. Even assuming a low density for ether, its elasticity in the above relationship would equal that of steel, if it has to transmit light at its enormous speed. Low density and high elasticity for the same substance are contradictory properties. Thus, there came a dead end on the postulation of the properties of ether. And this seems to have happened because it was presupposed, all along – after the overthrow of the Cartesian philosophy and the start

¹ A History of the Theories of Aether and Electricity, Sir Edmund Whittaker

of Newtonian mechanics – by most natural philosophers that ether’s properties must necessarily be similar to that of a material medium. While the above difficulties related to the development of the vortex- structure of matter were yet to be addressed, Einstein’s Theory of Relativity (1905), proposed around the same time, postulated the medium of space as an *empty extension*, assigning no point of space with a velocity-vector (hereafter, termed as velocity field). This made the very existence of ether superfluous.

The space-vortex structure of electron (described later, in detail), based on my earlier works (see Appendix, A 5), provides solutions to both of the above problems. Briefly stated these are: The high elasticity required for the fluid-ether, as pointed out above, is avoided by postulating it as a *nonmaterial*, incompressible fluid, that is, a fluid-entity devoid of any known property of matter, such as mass, density, discreteness, viscosity, elasticity, or compressibility. Further, if the properties of an electron are required to be derived from the first principles, then an assumption must be made as to a mass-less and charge-less fluid that, as a vortex, can form the structure of the electron. It will be seen that the proof of this assumption – that the universal substratum of space with *nonmaterial* properties (discussed in Chapter 4) has real existence – is provided by discovering from the space vortex structure the properties of electron (mass, charge, inertia, gravity, etc.), and by explaining, in physical as well as quantitative terms, its behaviour as experimentally observed. The other problem, of the outward dissipation of vortex motion, is avoided by introducing a *discontinuity* in energy-distribution at electron vortex center, as discussed further.

3.1 Defining Terms commonly used to qualify Euclidian Space

Certain terms, presently used in contemporary physics to describe the space medium, have no rigid definitions. The result is that their use does not clearly express the ideas behind the terms, leaving ambiguity and vagueness. For instance, the term “empty space” is used to mean “a volume of space without matter”, and also used as “a volume of space without matter, even though it is pervaded with fields”. Empty space is also sometimes used for a “void” or “nothingness”. For instance, in the Special Theory of Relativity (STR, 1905), Einstein wrote: “The introduction of a luminiferous ether will prove to be superfluous Nor (we shall) assign a velocity vector to a point of the empty space in which electromagnetic processes take place”. Here by “empty space” he means “absolute vacuum without matter and also without ether”. Hence, we can conclude that in STR, the “empty space” means a void or nothingness. Yet, Einstein calls it “empty space” and presupposes that light (electromagnetic field) can exist in it and transmit through it. It has been shown (Tewari) that a void-space can not sustain fields or matter. In order to be more specific about the properties of space, the following definitions apply.

Absolute vacuum/vacuum: A three dimensional, Euclidean, Mass-less volume without matter (Matter has mass as its basic property), but with or without electrostatic, magnetic, gravitational, or electromagnetic fields. (fields are mass less entities, as shown later).

Empty space: Same as the Absolute vacuum.

Void: A volume without the Absolute vacuum (field less, energy less).

Nothingness: Same as a void.

Velocity field: The fluid space which when in vortex-circulation or in linear motion, possesses velocity at each point. The velocity of these space points is defined as the “Velocity field”.

Acceleration field: The acceleration of space points is defined as the “Acceleration field”.

Chapter 4

Though One, Brahman is the Cause of the many.
Brahman is the unborn in which all existing things abide.
The One manifests as the many. The formless puts on forms.

Rig Veda

STRUCTURAL RELATIONSHIP BETWEEN SPACE AND MATTER

4.1. Postulates of Space Vortex Theory

1. The medium of space, throughout the universe, is an eternally existing, nonmaterial, continuous, isotropic, fluid substratum.
2. The medium of space has a limiting flow speed equal to the speed of light relative to the absolute vacuum, and a limiting angular velocity, when in a state of circulating motion.
3. The medium of universal space is eternal and inherent with motion.

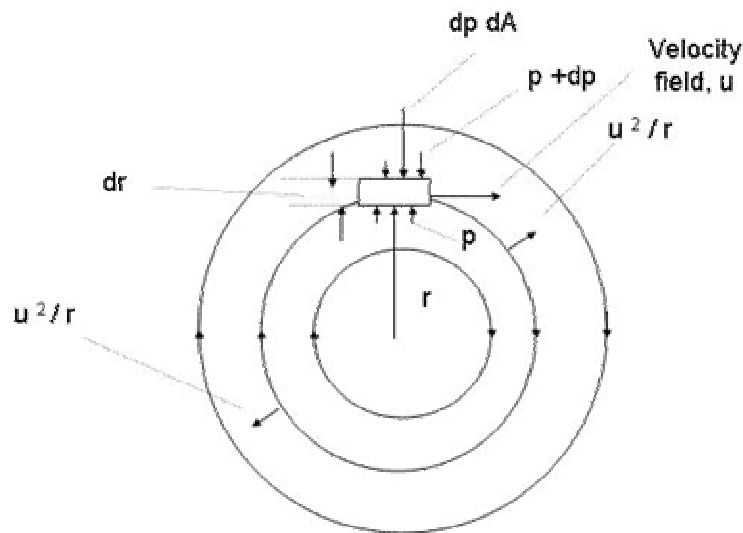

Figure 4.1 Irrotational Vortex

4.2 Break down of the fluid space

The process of creation of the electron requires a breakdown of the flow of the fluid medium of space. Fig. 4.1 shows an irrotational circular vortex of space with concentric streamlines. Consider an element of space of volume $dAdr$, as shown, on which a tangential velocity field u is acting. If this vortex pertained to

a viscous fluid of density ρ , the mass of the element will be: $dm = \rho dA dr$. There will be a pressure differential on the two surfaces of the element as shown. The two equal and opposite forces acting on the element will be: (a) an inwardly directed, radial, net pressure force and (b) a centrifugal force, giving the relation: Force = net pressure force = centrifugal force = $dp dA = dm \times u^2/r = (\rho dA dr) u^2/r$, from which:

$$\frac{\text{Force}}{dm} = \frac{(dp dA)}{(\rho dA dr)} = \frac{u^2}{r} \quad (4.1)$$

In an irrotational circular vortex, it can be shown that the velocity of a space-point, distant r from the vortex center, is given by:

$$u r = \text{constant} \quad (4.2)$$

When a vortex of *mass less* space is considered, there is neither the inward force (on the element) due to the pressure-differential, nor an outward centrifugal force, because the property of mass is common to the origin of both these forces. On a circular stream line, and at each of its points, the velocity field u creates a radial outward acceleration field u^2/r that, acting simultaneously on diametrically opposite points, tends to create a *tearing action* to split open the *continuous* space. If the speed of the space-circulation reaches the limiting speed c , which is the speed of light in the absolute vacuum, and the velocity-field gradient around the center of the vortex becomes the postulated limiting angular rotation ω , the space breaks down creating a spherical void (Fig. 4.2), which is defined as a field-less, energy-less and space-less volume of *nothingness* at the vortex center. The radius of the void created follows the relation, as determined by the ratio:

$$\omega = \frac{c}{r_e} \quad (4.3)$$

4.3 Stability of the void

Refer to Fig. 4.3 showing a diametrical cross section of the spherical void by the plane Y-Z. The circle C rotating around the Y-axis traces a sphere. The point P_z , at the intersection of C and the Z-axis, will have a tangential velocity c (down the paper) the velocity at which the flow of the fluid-space breaks down. The radius r_e of C, from (4.2), is determined by the ratio c/ω . Consider a point P at the circle C that has the Y-coordinate, $r_e \sin\theta$: it will have a tangential velocity $\omega r_e \sin\theta$ (down the paper at P) provided P too has the same angular velocity ω similar to P_z . The velocity gradient at P_z is c/r_e , which is also the velocity gradient at P, that is, $\omega r_e \sin\theta / r_e \sin\theta$, or ω . Thus, though the tangential velocity of space varies from zero at P_y (located at the axis, Fig. 4.3) to the maximum value c at P_z in the diametrical plane, the velocity gradient for all the in-between points remains constant at ω (Postulate 2). Under these considerations the geometry of the void created at the vortex center due to the breakdown of the flow of space is concluded to be *spherical*. It is shown below that the void is dynamically stable. The creation of the void reverses the direction of the outward acceleration field (Eq. 4.1) that created the void, because the void (enclosed within a sphere, hereafter, referred as the *interface*) being an empty volume without any “circulating space” or “energy”, is now at zero potential relative to space surrounding it. Therefore, the acceleration field in Fig. 2 is shown inward. As described above, ω is the limiting *velocity gradient* c/r_e at the point P_z just prior to creation of the void. At each point of the interface circle, cut by a diametrical plane at right angles to the Y-Z plane (Fig. 4.3), the tangential velocity c produces maximum radial and inward acceleration, c^2/r_e .

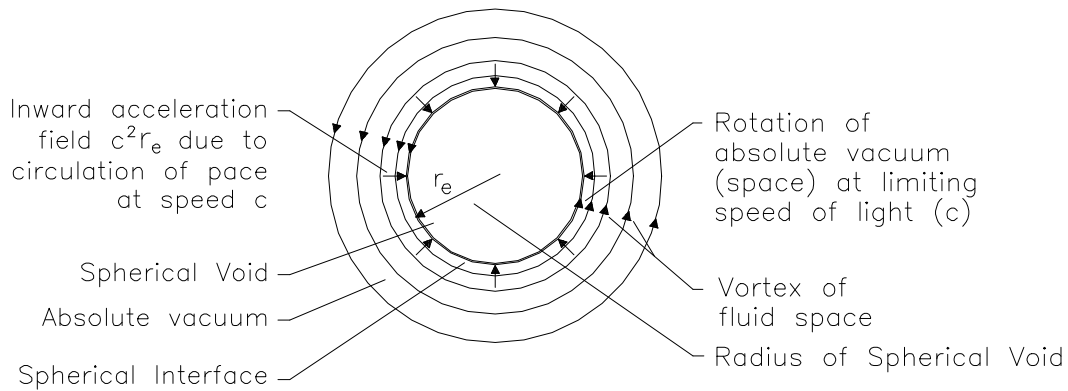

Absolute vacuum possesses non-material properties of incompressibility, zero-viscosity, continuity & mass-lessness of an ideal fluid; fieldless & energyless spherical-void is created due to limiting rotation & breakdown of absolute vacuum.

Fig. 4.2 Vortex in electron structure

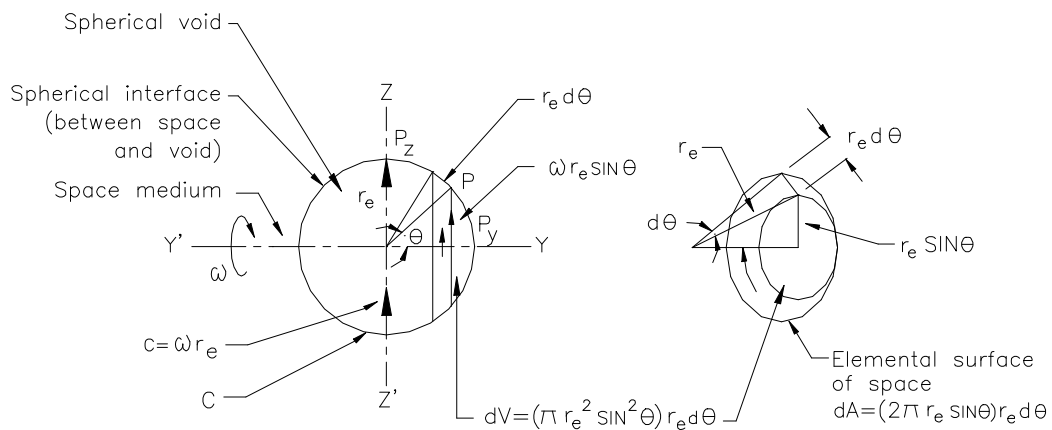

$$\omega = \text{Angular velocity of spherical interface around } y-y'$$

Void = Fieldless spherical hole in space

$$\text{Void-radius } r_e \simeq 4 \times 10^{-11} \text{ Cm}$$

Fig. 4.3 Velocity Field on Interface

The acceleration field at P is $(\omega r_e \sin\theta)^2 / r_e \sin\theta$ along $r_e \sin\theta$. The interface, though constituted of spinning fluid-space, on account of the constancy of ω on each of its points, rotates similar to a surface of a rigid spherical shell of negligible wall thickness. The stability of the void is due to the following two factors. Consider the circular section of the interface with the diametrical plane (Fig. 4.2). The radial velocity gradient (ω) is c/r_e . If the void shrinks to a smaller radius, the

value of ω increases proportionately; which is not possible per Postulate 2; the void thus enlarges back to the original size. In the case where the void tends to grow to a larger size, the *inward* acceleration field c^2/r_e opposes this increase and any increase in r_e decreases the velocity gradient ω to lesser magnitude, which is no more sufficient to sustain the void. The sphere of the void is thus reduced to its original size. The other factor is the property of the non-viscosity of space, which maintains the space-vortex eternally, except for its annihilation on meeting a similar vortex, with an oppositely oriented velocity field (discussed later). Further, the energy-less-void being a region of zero potential, the inward acceleration field c^2/r_e on the interface prevents dilation of the streamlines, thereby, preventing dissipation of the space-circulation away from the interface. Thus, the void maintains its dynamic stability—its volume being regulated due to the constancy of ω and, consequently, the constancy of c and r_e , dictated by the absolute¹ properties of the medium of space.

4.4 Fundamental particles of matter

If there is only one fundamental particle of matter, it is inconceivable that the universe has different kinds of “spaces” or many structures with varying basic properties. Hence, it has been postulated that the most basic property of the universal medium of space is expressed by a single universal constant ω that limits its angular rotation and leads to the creation of a fundamental stable vortex. While the void of a *definite volume* is enclosed within the space-vortex, the vortex itself extends throughout the whole universal-space through its *velocity field*². The space-vortex structure with a fixed volume of dynamically stable void at its center is defined as the fundamental particle of matter. The properties of “electric charge” and “mass” of the fundamental particle, and the “energy fields” associated with its structure are derived in the following pages.

4.5 Generation of fields

The space in circulation at speed c within the volume of the spherical void prior to its creation is, qualitatively, the basic state of energy³. At the instant of the creation of the void, this energy is pushed out from within the void, and distributed in continuous space as continuously varying gravity and electrostatic fields. The fields, so created, emanating from the interface of the fundamental particle, become integral with the whole of universal space. On account of the property of the non-viscosity of space, the void enclosed within the dynamically stable interface at the center of the vortex, and the above fields, remains eternally existent without any loss of their strength. The fundamental particle described above has been identified below through its properties as the electron itself.

4.6 Unit Electric Charge

Electric charge is the effect of the space-circulation produced on the interface of a fundamental particle of matter. It is derived as follows. Refer to Fig. 3. Con-

¹ Properties of space, being non-material in nature, are defined to be absolute; unaffected by various conditions of temperature and pressure as applicable to material media.

² The motion of space leads to the generation of “the velocity field”.

³ The quantitative definition of energy is given further.

sider an elemental surface on the interface, which has an area: $dA = 2\pi r_e \sin\theta r_e d\theta$. The tangential velocity of space at each point of the elemental surface is $\omega r_e \sin\theta$. The electric charge on the elemental surface is defined from the first principles as the *surface integral of the tangential velocity of space on each point of the surface*: $dq = 2\pi r_e \sin\theta r_e d\theta \omega r_e \sin\theta$. Substituting from (4.2), $\omega r_e = c$, in the above equation: $dq = 2\pi c r_e^2 \sin^2\theta d\theta$. Integrating for the total electric charge q_e , varying θ from 0 to π :

$$q_e = 2\pi c r_e^2 \int_0^\pi \sin^2\theta d\theta = \left(\frac{\pi}{4}\right) 4\pi r_e^2 c \quad (4.4)$$

The *surface integral of the tangential space velocity on the interface is defined as the unit of electrical charge of the fundamental particle of matter*. The dimensions of electric charge from (4.4) are: $q_e = L^3/T$. In CGSE system of units:

$$\frac{cm^3}{s} = CGSE - unit \quad (4.5)$$

Substituting in (4) the experimentally determined value of the electric charge of an electron (4.8×10^{-10} CGSE); the speed of light in absolute vacuum (3×10^{10} cm/s); and using the relationship (5), the radius of the interface enclosing the void is calculated as: $r_e = 4 \times 10^{-11}$ cm. A comparison with the classical electron radius, which in modern textbooks is shown as: 2.82×10^{-13} cm, revealed that r_e should be about 142 times smaller. However, the following reference supported the results obtained from (4.4).¹ “There are several lengths that might aspire to be characteristic of the dimensions of the electron. If we proceed from modern theoretical electrodynamics, which has been established better than any other field theory, the conclusion seems to be that the electron has enormous dimensions, not 10^{-13} cm, as expected from classical physics, but 10^{-11} cm (a hundred times greater!)”. This value of the radius of electron (10^{-11} cm), and its closeness with the radius of the spherical void derived above from Eq.4.4, suggested that the “fundamental particle of matter” described earlier is itself the electron—already discovered by the close of the 19th century. An electron moving away from an observer (electron axis coinciding with the line of motion) is seen as a positron by another observer towards whom this electron is approaching. Fig. 4.4 shows, qualitatively, attractive and repulsive forces between these particles through interaction of their velocity fields; while quantitative relationships follow further.

¹ Philosophical Problems of Elementary Particles Physics; George Yankovsky; Progress Publishers, Moscow, 1968

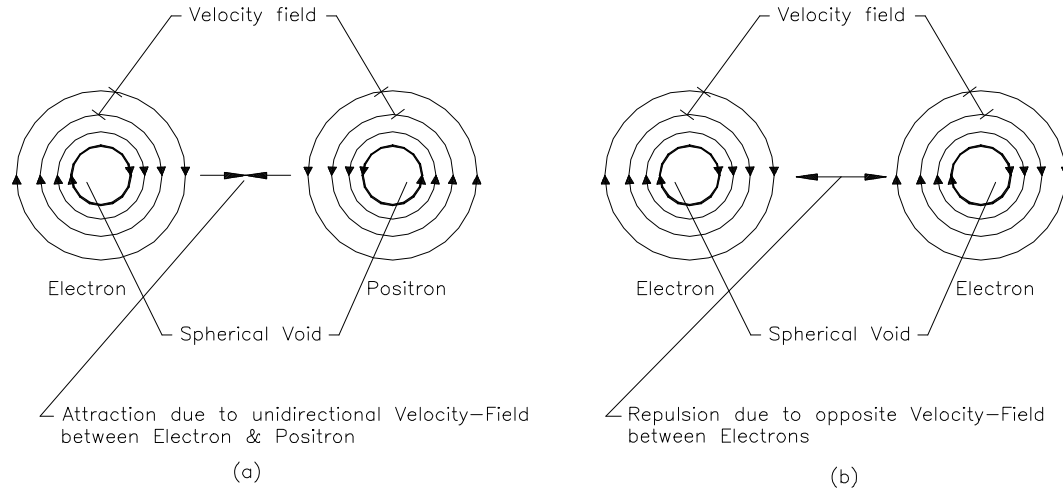

Fig. 4.4 Attractive & Repulsive Forces due to Velocity Fields

In (a) of Fig. 4.4, the velocity-field, u , in between the particles is increased due to the superposition of the fields. From (4.2), an increase in u results in the proportionate decrease of r ; and hence the particles are brought closer with an attractive force between them. In (b) of Fig. 4.4, due to the decrease of the velocity field in between the particles, r has to increase proportionately and this causes a repulsive force between the similar particles. Quantitative relationships are derived further.

4.7 Fundamental mass

The property of mass in the fundamental particle of matter (electron) arises due to the breakdown of space circulation at the center of the electron, and consequent creation of a dynamically stable spherical void associated with gravitational as well as electrostatic fields in space. The derivation of the mass of the electron from the vortex structure is as follows. Refer to Fig. 3. Consider an element of void volume, dV , within the spherical interface: $dV = (\pi r_e^2 \sin^2 \theta) r_e d\theta = \pi r_e^3 \sin^2 \theta d\theta$. The tangential velocity of space acting at the interface of this element is, $\omega r_e \sin \theta$. The physical process of creation of mass, dm , of this element is imagined due to volume, dV , of the fluid space being pushed out, at the time of void creation, at the above speed, $\omega r_e \sin \theta$, tangentially through the interface. The mass of the elemental void volume is defined from the *first postulates* as: $dm = dV (\omega r_e \sin \theta) = dV (c \sin \theta)$. Substituting the value of dV : $dm = (\pi r_e^3 \sin^2 \theta d\theta) \omega r_e \sin \theta = (4\pi/3) r_e^3 c$. Integrating for the total mass m_e , varying θ from 0 to π :

$$m_e = \left(\frac{4\pi}{3} \right) r_e^3 c \quad (4.6)$$

$$\text{Fundamental mass} = \text{Fundamental void volume} \times c \quad (4.7)$$

The volume-integral of space-circulation velocity within the void, at the instant of its creation, is the mass of the fundamental unit of matter (electron). Here, the difference between rest mass and relativistic mass is not made as explained. It was earlier shown that the void at the electron center is dynamically stable with radius r_e and space circulation c . This leads to the creation of only one size of stable void. Therefore all the particles of matter, nuclei and atoms will have their masses in exact multiples of electron mass (analyzed further below). The mass of the electron during motion relative to space will remain constant up to speed c because the fluid-space ahead of a moving electron can be displaced up to a maximum speed c only. Thus the volume of the void remains constant; therefore mass of the electron, which is proportional to the volume of the void (4.7), also remains constant. The relativistic increase in mass of the electron at speeds closer to the light speed, as experimentally observed, is due to the reaction of the fluid space against the central interface in electron structure due to production of an additional acceleration field (discussed in Chapter10). The proportionality of mass to the limiting velocity field (c) and also to the volume of the central void (4.6) shows that *mass is not energy*. “*Mass is proportional to energy*” is a more accurate statement.

4.8 Dimensions and the unit of mass

The dimensions of mass from Eq.6 are: $m_e = L^4/T$. Therefore, in the CGS system of units, the unit of mass is: cm^4/s . With the use of the experimentally determined mass of the electron, the computed mass of a molecule of water, and the known numbers of molecules in one cm^3 of water; a relationship between “ cm^4/s ” and “gram” is approximately determined below. From the charge equation (4.4), the electron radius is:

$$r_e = \left(\frac{q_e}{\pi^2 c} \right)^{1/2} \quad (4.8)$$

The electron charge is experimentally determined as 4.8×10^{-10} CGSE. Expressing CGSE as cm^3/s from (5), $q_e = 4.8 \times 10^{-10} \text{ cm}^3/\text{s}$, and substituting this value of electron charge and the value of c in (4.8):

$$r_e = \frac{(4.8 \times 10^{-10} \text{ cm}^3/\text{s})^{1/2}}{(\pi^2 3 \times 10^{10} \text{ cm/s})^{1/2}} = 4 \times 10^{-11} \text{ cm} \quad (4.9)$$

With the above radius of the interface (void), its volume is: $V_e = (4\pi/3) (4 \times 10^{-11} \text{ cm})^3 = 2.67 \times 10^{-31} \text{ cm}^3$. The mass of the electron, experimentally determined, is $9.11 \times 10^{-28} \text{ g}$. Although the concept of density in its structure is not applicable because of the central void, the ratio of the electron mass and the volume of its void will be indicative of the proportionality of the “quantity of mass” within a “unit volume” of void. From above, this ratio, m_e/V_e is: $9.11 \times 10^{-28} \text{ g} / 2.67 \times 10^{-31} \text{ cm}^3 = 3.42 \times 10^3 \text{ g/cm}^3$. One molecule of water is about $2.88 \times 10^{-23} \text{ g}$. Since the mass of a water molecule has to be an exact multiple of the electron mass, the ratio, m_e/V_e , calculated above for the electron, will also be applicable to the water molecule. Using this ratio, the void volume in the water molecule is: $V_H = (2.88 \times 10^{-23} \text{ g}) / (3.42 \times 10^3 \text{ g/cm}^3) = 8.4 \times 10^{-27} \text{ cm}^3$. One cm^3 of water has 3.34×10^{22} molecules, the void-volume in one cm^3 of water can be calculated as: $(3.34 \times 10^{22}) (8.4 \times 10^{-27} \text{ cm}^3) = 2.8 \times 10^{-4} \text{ cm}^3$. From the mass-equation (4.6), and mass and void-volume

relationship (4.7), the equivalent mass that one cm^3 of water, due to its void content, has is: $(2.8 \times 10^{-4} \text{cm}^3) (3 \times 10^{10} \text{cm/s}) = 8.4 \times 10^6 \text{cm}^4/\text{s}$. Since, the mass of one cm^3 of water is one gram, from above, we have the relationship:

$$\text{gram} = 8.4 \times 10^6 \text{cm}^4/\text{s} \quad (4.10)$$

Alternatively, the above relationship can be found through a simpler method as follows. Substituting the values of electron radius r_e from (4.9) and the experimentally determined mass, in mass equation (4.6): $9.11 \times 10^{-28} \text{g} = (4\pi/3) (4 \times 10^{-11} \text{cm})^3 (3 \times 10^{10} \text{cm/s})$.

From which:

$$\text{gram} = 8.8 \times 10^6 \text{cm}^4/\text{s} \quad (4.11)$$

The results obtained in (4.10) and (4.11) are close; from the average of both:

$$\text{gram} \approx 8.6 \times 10^6 \text{cm}^4/\text{s} \quad (4.12)$$

4.9 Energy in electron structure

Linear and accelerating motion of space, are the basic states of energy. The circulation of space, forming the electron's interface and spreading throughout the universal space, is the structural energy of the electron; it is computed as follows. Refer to Fig.3. Consider, within the interface, an elemental "disc of void" of volume, $dV = (\pi r_e^2 \sin^2 \theta) r_e d\theta = \pi r_e^3 \sin^2 \theta d\theta$, which is created due to the displacement of space through the interface at the tangential velocity, $\omega r_e \sin \theta$, or, $c \sin \theta$ (since $\omega r_e = c$), at the instant of the electron's creation. The mass of this disc element, as defined in (4.7) is:

$$dm = dV(c \sin \theta) = (\pi r_e^3 \sin^2 \theta d\theta) c \sin \theta = \pi c r_e^3 \sin^3 \theta d\theta \quad (4.13)$$

The disc element has an area at the interface equal to $(2\pi r_e \sin \theta) r_e d\theta$; and has an inward radial acceleration field at each point on it such that $a_f = \omega^2 r_e^2 \sin^2 \theta / r_e \sin \theta = c^2 \sin \theta / r_e$. Consider the process opposite to the void creation — the case of collapse of the interface to zero radius (as it happens during annihilation, which is discussed later), when each point at the interface of the elemental disc will be displaced along the radius $r_e \sin \theta$ with the above inward acceleration field acting on it. The energy released due to collapse of the void-disc-element is defined as: $dE = dm \cdot a_f$ (field displacement) $= (\pi c r_e^3 \sin^3 \theta d\theta) (c^2 \sin \theta / r_e) r_e \sin \theta = \pi c^3 r_e^3 \sin^5 \theta d\theta$. Integrating, varying θ from 0 to π , to obtain the total energy released due to the collapse of the spherical void yields the creation energy

$$E = \left(\frac{4}{5} \right) \left(\frac{4\pi r_e^3 c}{3} \right) c^2 = \left(\frac{4}{5} \right) m_e c^2 \quad (4.14)$$

which is obtained when the mass-equation (4.6), is used and $(4\pi r_e^3 c/3)$ is substituted for m_e . Here we see an equation discovered by Einstein (and others). However, the physical meaning as to why the speed of light "c" appears in the mass-energy equation is now explained. It signifies the actual maximum possible space-circulation in the structure of fundamental matter, even when it is stationary relative to the medium of space.

4.10 Angular momentum of electron vortex

The intrinsic angular momentum of the spinning interface of the electron is found as follows. Refer to Fig. 4.3. Consider an element of void-volume $dV = \pi r_e^2 \sin^2 \theta r_e d\theta$, which, at the interface, has the tangential velocity of space, $\omega r_e \sin \theta$. Its mass from (4.6) will be: $dm = dV \omega r_e \sin \theta = (\pi r_e^3 \sin^2 \theta d\theta) c \sin \theta = \pi c r_e^3 \sin^3 \theta d\theta$; and angular momentum, $dL = dm (\omega r_e \sin \theta) r_e \sin \theta = (\pi c r_e^3 \sin^3 \theta d\theta) c r_e \sin^2 \theta = \pi c^2 r_e^4 \sin^5 \theta d\theta$. Integrating, varying θ from 0 to π , to obtain the angular momentum for the whole interface:

$$L = \pi c^2 r_e^4 \int_0^\pi \sin^5 \theta d\theta = \left(\frac{4}{5} \right) \left[\frac{4\pi}{3} r_e^3 c \right] c r_e = \left(\frac{4}{5} \right) m_e c r_e \quad (4.15)$$

in which m_e has been substituted for the quantity within the bracket as per the mass-equation (4.6).

The intrinsic angular momentum of the electron is directly proportional to its mass, radius, and the speed of light.

4.11 Spin Magnetic Moment

Refer to Fig. 4.3. Consider an infinitesimal ring-element of charge: $dq = dA \omega r_e \sin \theta$. The Magnetic moment due to this charge element is defined as: $d\mu = dq (\omega r_e \sin \theta) r_e \sin \theta = (2\pi r_e \sin \theta r_e d\theta) (\omega r_e \sin \theta) (\omega r_e \sin \theta) r_e \sin \theta = 2\pi c^2 r_e^3 \sin^4 \theta d\theta$. Integrating, varying θ from 0 to π , to obtain total magnetic moment of the electron:

$$\mu = (2\pi c^2 r_e^3) \left(\frac{3\pi}{8} \right) = \left(\frac{3}{4} \right) \left(\frac{\pi}{4} \right) (4\pi r_e^2 c) c r_e = \left(\frac{3}{4} \right) q_e c r_e \quad (4.16)$$

The magnetic moment of electron is directly proportional to its charge, radius, and speed of light.

4.12 Electrostatic Field Energy

An expression for the electrostatic field of the electron at a point in space is derived below from the vortex structure of the electron. Refer to Fig. 4.5. Consider a sphere of radius r , cut by a plane parallel to the X-Z plane containing a circle C of radius $p_1 y_1$. The radius r (op_1) passes through the interface of the electron at point p , and meets C at p_1 . In the diametrical plane X-Z of the interface (void), the point z at the interface will have a tangential velocity of space ωr_e , that is c (down the paper); the tangential velocity of space at the point z_1 (in the plane X-Z) down the paper, from (4.2), will be cr_e/r . The velocity of space u_2 , at p , tangential to the circle C_1 , is $\omega r_e \sin \theta$, whereas, at p_1 tangential to the circle C, the velocity of space from (4.2) is: $u_1 = (\omega r_e \sin \theta) r_e \sin \theta / r \sin \theta = cr_e \sin \theta / r$. The inward acceleration field at p_1 , along $p_1 y_1$ is:

$$a_f = \frac{u_1^2}{r \sin \theta} = \frac{(cr_e \sin \theta / r)^2}{r \sin \theta} = \frac{c^2 r_e^2 \sin \theta}{r^3} \quad (4.17)$$

The component of a_f along the radius op_1 , from (4.17): $a_r = a_f \sin \theta = c^2 r_e^2 \sin^2 \theta / r^3$. The electric field E at p_1 along the radius op_1 is defined to have the following relationship with the radial space acceleration field a_r derived above:

$$\frac{dE}{dr} = a_r = \frac{c^2 r_e^2 \sin^2 \theta}{r^3}, \text{ from which } E = \frac{-c^2 r_e^2 \sin^2 \theta}{2r^2} \quad (4.18)$$

which is an *inward* field created by the electron (also by a positron, if the same is considered) with the minimum value of r equal to r_e , because the void is *fieldless*.

The magnitude of E at the interface, along the Y -axis, for $\theta = 0$, is zero; and in the transverse plane (E_{tr}) for $\theta = \pi/2$, at the point z_1 distant r from the origin is:

$$E_{tr} = \frac{-c^2 r_e^2}{2r^2} \quad (4.19)$$

The maximum value of E is at the interface in the transverse plane X - Z for $\theta = \pi/2$, and $r = r_e$

$$E_{\max} = \frac{-c^2}{2} \quad (4.20)$$

The electric potential ϕ at z_1 from (4.19) is given by: $d\phi/dr = E_{tr}$, from which, $d\phi = E_{tr} dr = (c^2 r_e^2 / 2r^2) dr$, and $\phi = -c^2 r_e^2 / 2r$. In an irrotational vortex, from (4.2), $cr_e = ur$. Substituting this in the above equation, we have,

$$\phi = \frac{-cr_e(ur)}{2r} = \frac{cr_e u}{2} \quad (4.21)$$

From (4.21) it is seen that in a space vortex, the velocity field u , is the most fundamental field in the universe, which creates the electrostatic potential. Attraction between an electron and a positron (Fig. 4.4a) can be calculated by using Coulomb's equation for interaction between charges with the concept of the electric field derived above, and also explained through superposition of velocity fields as stated earlier. Coulomb's law, which was experimentally determined, can be derived from (4.19) as follows. Multiplying and dividing the right-hand side of (19) by, $(\pi/4)4\pi$, and rearranging terms: $E_{tr} = -c^2 r_e^2 (\pi/4)4\pi / 2r^2 (\pi/4) 4\pi = -2c [4\pi r_e^2 c \pi / 4] / \pi 4\pi r^2$. Replacing the quantity in the bracket by q_e from the charge-equation (4.4), we have,

$$E_{tr} = \frac{-2/\pi(c/4\pi)q_e}{r^2} \quad (4.22)$$

The above equation shows that the electric field, that is, "force per unit charge", is directly proportional to the charge, and inversely proportional to the square of the distance from the charge, which is as per the Coulomb's law; and for spherically symmetric charge distribution is:

$$E = \frac{(1/4\pi\epsilon_0)q_e}{r^2} \quad (4.23)$$

4.13 Dielectric constant, permeability constant, Gauss' law

Using equations (4.20, 4.23), and charge equation (4.4), we derive the dielectric constant of the vacuum is derived as

$$\epsilon_0 = \frac{\pi}{2c} \quad (4.24)$$

The dielectric constant of vacuum is inversely proportional to the speed of light. A check can be made for the above equation by substituting in (4.23), $\pi/2c$, in place of ϵ_0 : $E = 1/4\pi (\pi/2c) q_e/r^2 = (c/2\pi^2) q_e/r^2$.

Expressing q_e in CGSE and inserting the value of c , $E = [(3 \times 10^{10} \text{ cm/s})/2 \times (3.14)^2] 4.8 \times 10^{-10} \text{ CGSE}/r^2 = (0.73) \text{ CGSE}/r^2$. Two CGSE unit charges, located 1 cm apart, require that the above computed coefficient, 0.73, should be 1; the difference is negligible.

From Maxwell's equation it followed that $c = 1/(\mu_0 \epsilon_0)^{1/2}$, where μ_0 is the permeability constant of the vacuum. (From this basic relationship it had been possible to predict that light is an electromagnetic effect). Expressing ϵ_0 in terms of c as derived in (4.24), the above equation becomes $c = 1/(\mu_0 \pi/2c)^{1/2}$; from which we have:

$$\mu_0 = \frac{2}{\pi c} \quad (4.25)$$

It is seen that like the dielectric constant, the *permeability constant of the vacuum is also inversely proportional to the speed of light.*

Using equation (4.18) for the electric field, charge equation (4.4), and relationship (4.24) for the dielectric constant, Gauss' law is derived (see Appendix, A 2) $\Phi_E = (-2/3) q_e/\epsilon_0$.

4.14 Electrostatic energy in electron vortex

The electrostatic energy U in the velocity field of the electron vortex is calculated (see Appendix, A1) using (4.18) for the electric field, (4.24) for the dielectric constant, and mass equation (4.6), as:

$$U = \left(\frac{\pi}{10} \right) m_e c^2 \quad (4.26)$$

In the integral to compute the above energy U , the lower limit of the radius from the electron center is the interface radius r_e of the electron; not zero, as is the case with a point-charge, which would lead to infinite energy in its electrostatic field. The electrostatic energy (4.26) is less than the total electron creation energy in space derived in the mass-energy equation (4.14). The difference between the two (about $(1/2) m_e c^2$, given below) should appear as the electron's gravitational energy in space.

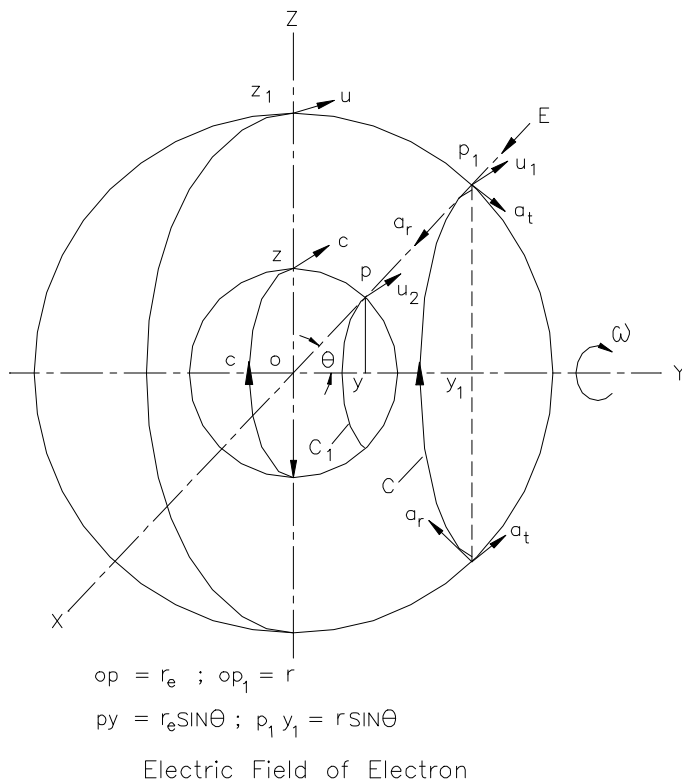

Fig. 4.5

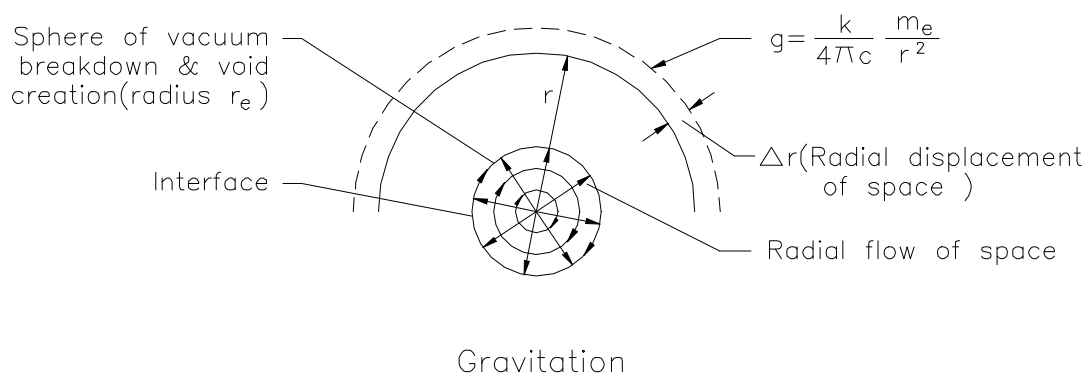

Fig. 4.6

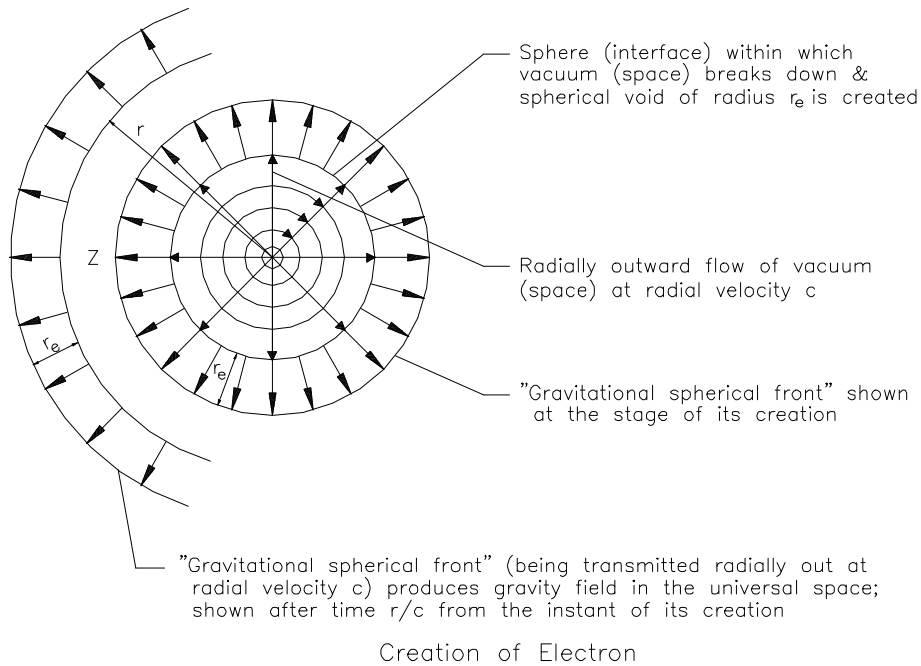

Fig. 4.6 a

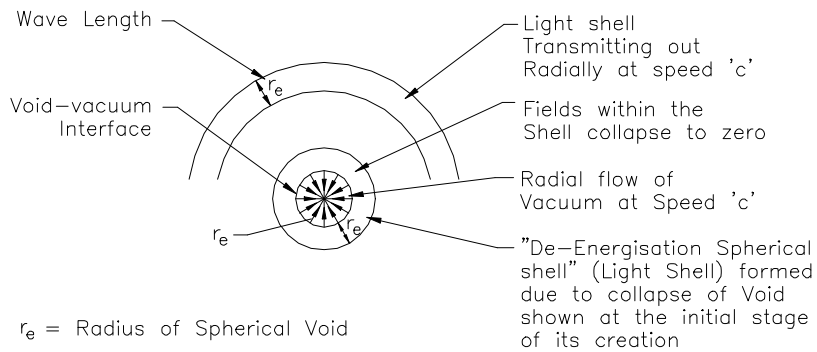

Fig. 4.7

4.15 Gravitation

Gravitational effects arise from the very structure of the electron. Consequent to the creation of the spherical void at the electron center due to the limiting speed of space-circulation, universal space is gravitationally energized (Fig.4.6, 4.6a) through the transmission of gravitational potential, a process starting from the interface of the electron and proceeding outwards at speed c , the limiting speed for transmission of fields / potentials in space. The energy used for creation of each electron is retained in space as gravitational / electrostatic potential—there being no reduction in the overall content of the universal energy due to the creation of electrons. The creation of electron voids requires energy (4.14) of the magnitude, $(4/5) m_e c^2$, out of which as seen from (27), $(\pi/10) m_e c^2$, is distributed in space as electrostatic energy; whereas, the remaining, about $(1/2) m_e c^2$, stays in space as gravitational potential. As shown in the figure, the gravitational, g , of the electron is derived¹ as:

$$g = \frac{(k/4\pi c)m_e}{r^2} \quad (4.27)$$

in which k is a “constant of proportionality” with dimensions of, $1/T^2$, so that the dimensions of g from (27) are: L/T^2 . Since the electron is identified as the fundamental particle of matter, (4.27) is the equation of the gravity field applicable to all nuclei, atoms and matter in general. A

Gravitational constant for an atom of average atomic mass has been derived (Section 5.1) using (4.27).

4.16 The annihilation of electrons and positrons—the fundamental nature of light

With the discovery of the positron (1932) a new phenomenon of the annihilation of electrons and positrons was observed. During this process, the spherical interfaces of the particles, under strong electrical attraction, are brought together and at a very close range, the particles superimpose on each other; thus stopping the oppositely directed space-circulations around their interfaces which leads to a collapse of their central voids. In this process mass vanishes and light is produced. It is evident that the *void interiors* within the interfaces of the electron and positron, being energy-less, cannot *emit* any kind of energy (such as photons). The energy (velocity and acceleration fields) in the vortex structure of these particles pervades the whole of universal space both before annihilation; and following annihilation. Following the annihilation, the process in which the electromagnetic and gravitational potentials are reduced to zero, a single shell of light, seen as a pulse, initiates from the superimposed interfaces, (Fig. 4.6).

When the interfaces of the particles superimpose, there is only one spherical-void common to both particles; space flows radially at its maximum speed c , into the void (Fig. 4.7). The duration of collapse is $\Delta t = r_e / c$. During this period, a

¹ Universal principles of Space and Matter – A Call for Conceptual Reorientation

shell of radial width, $\Delta t c$, that is, $(r_e/c) c = r_e$, is formed, and transmitted outward at speed c relative to space. Within the wavelength, the space points undergo acceleration: $c / (r_e/c)$, which is c^2/r_e . (For light produced due to thermal radiation, acceleration of points within the wavelength is c^2/λ , where λ is the wavelength¹. The transmission of the shell is a process that de-energizes the space medium, erasing for all the time the gravitational and electrostatic potentials that were created at the time of the creation of the now non-existent electron and positron. *The spherical shell produced due to the dying of potentials, a process of the de-energizing of the space substratum consequent to the electron / positron annihilation is the fundamental phenomenon known as light.*

The wavelength of the annihilation light (Fig. 4.6) is equal to the electron radius. *This light, with a single shell, does not have the concept of frequency applicable to it.* In the case where there are several annihilations taking place at a point one after the other *without absolutely any time gap between the successive annihilations*, the frequency can be defined as the number of shells formed in unit time. Also, if the time for the formation of a *single shell* is Δt , then frequency f can be defined as: $f = 1/\Delta t$. This mathematical operation does not mean that the single-shell-light has the property of frequency per the conventional definition of frequency ($c = \lambda f$). The interrelationship between light and gravity and the derivation of the gravitational and Planck constants have been analyzed elsewhere (Section 5.2).

4.17 Magnetic Fields

The electron has an axis of rotation at right angles to the diametrical plane of its space vortex (Figs. 4.2, 4.3). The pattern of the circular magnetic field distribution observed around a current carrying conductor, though of a representative nature, gives an indication that the natural motion of an electron in electric current flowing in a conductor is along the axis of its vortex rotation because the streamlines of the fluid-space in the electron vortex are concentric with the electron axis (Fig. 4.2). Keeping in mind the similarity between the velocity-field in the space vortex of an electron and the magnetic field produced in a conductor due to its motion relative to space, the fundamental nature of the magnetic field associated with a moving electron has been determined [Chapter 10]. In Fig.4.8 an electron is shown moving linearly at uniform velocity v relative to space. It is seen that the direction of the maximum velocity field c at the interface is opposite to the magnetic field produced due to the electron's motion. The analysis [Chapter 10] shows that the magnetic field is an effect produced due to the reaction from the fluid space against the velocity field in the vortex on account of the electron's motion relative to space. It has also been derived that a point on a circle of radius r , concentric with the axis (Fig. 4.7) in the electron vortex, will have magnetic field; $B = vr_e/r$; which shows that B falls inversely to r .

With this relationship and also using the charge-equation (4.4) and the relationship (4.25), Ampere's law has been derived (Section 10.1). Due to the opposite direction of the magnetic field vector compared to the spin-direction in the electron vortex (Fig. 4.8), two electrons in parallel motion in the same direction

¹ Universal principles of Space and Matter –A call for Conceptual Reorientation

will magnetically attract, while, at the closest range (about 10^{-10} cm) they will electrically repel.

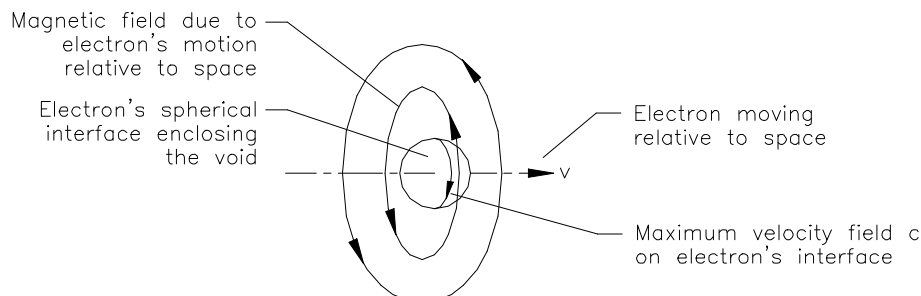

Magnetic field of electron in motion relative to space

Fig. 4. 8

4.18 Atomic Structure

The limitation on the creation of only one size of stable-void in the space vortex that produces stable fundamental mass and charge as basic units, very much simplifies the theory of atomic structure with the electron as the fundamental particle of the atomic nucleus. It follows that all stable particles will possess mass in exact multiples of the electron mass – there being no difference between a rest-mass and a relativistic-mass. Further, no *stable* particle, with mass less than electron mass, can ever be found naturally or created through artificial means in laboratory. *Unstable* particles with masses different from the electron mass are concluded to be some intermediate stage in the formation of stable particles like neutrons. Stable particles are enclosed in space-vortices that show the property of charge such as protons and alpha particles.

The *unstable* particles, showing a charge property, will also be enclosed within space vortices of varying strengths for the duration of their lifetime. A neutral particle, like a neutron, does not possess an overall space vortex around it and hence, without an electric charge, it remains neutral. All stable particles, neutral or charged, will have spin-axes of rotation. The charge of a particle, from the charge-equation, will be the surface integral of the velocity field on its surface. An electron and a positron in the closest possible range (about 10^{-10} cm) will undergo annihilation under electrical attraction, unless, the particles are translating *relative to space* and, thereby, producing a magnetic force of repulsion between them (Chapter 10).

Just as an electron is subjected to an “inward acceleration field” on its interface, all charged particles and nuclei, with space-circulation around them, will have an “inward acceleration field” tending to crush the particles. This inward force arises due to the existence of a void at the electron center, the vortex structure, and space-circulation around charged particles and the nuclei of atoms. Based on the above guiding principles, arising from the space-vortex structure of

the electron, its observed properties and behavior, the possible structures of nuclear particles are described below.

4.19 The primary unit

In Fig.4.9 is an assembly of two electrons and two positrons is shown. The velocity fields in between the particles are unidirectional, but in the region external to the assembly (not shown in the figure), will be in opposition. Therefore, this assembly (designated “primary unit”) will show overall electrical neutrality. The particles repel diagonally (F_r) due to similar charges, whereas, there is attraction between the adjacent particles (F_a) due to dissimilar charges. In addition, if the particles are also spinning around the center of their assembly, there will be a radial force, $m_e v^2/r$, which will reinforce the diagonal electrostatic repulsive force F_r . If the component force, $F_r \cos\theta$,¹ balances the attractive force F_a , the primary unit will be stable. Approximate computation¹ of the forces in the primary unit show, that *if rotation of the assembly is at speed c*, repulsive and attractive structural forces are nearly equal.

4.20 Neutrons

If a primary-unit is enclosed within a space vortex, it will be electrically charged and will be subjected to an inward acceleration field on the surface, thus making it a stable building block of matter. A neutron core can be assembled with several such charged units, in a similar pattern as electrons and positrons assemble into a neutral primary-unit. For a spherical assembly of equal numbers of electrons and positrons with a total of n particles, the radius is: $r = (n)^{1/3} r_e$. For a neutron, which should have 919 electrons and an equal number of positrons for overall neutrality with the superposition of their velocity fields, the radius is:

$$r_n = (1838)^{1/3} r_e \approx 12r_e \quad (4.28)$$

Calculations show that electrical repulsive forces in this assembly are about two times less than the electrical attractive forces between the adjacent primary units. The neutron should therefore be a stable particle but for the fact that it is known to have angular momentum; which signifies that it undergoes rotation.

It is found that a neutron rotating around its axis at speed c at the periphery (which will account for its maximum possible angular momentum), will not be stable; and consequently, its constituents (electron / positron) may be dislodged due to outward centrifugal force and emitted outward. This explains beta-decay and the cause as to why a neutron has a short half-life of only about 15 minutes.

4.21 Protons and the hydrogen atom

The proton structure contains a neutron enclosed within a space-vortex (Fig. 4.10), which accounts for the charge of the proton and in addition, creates an inward acceleration field. In the proton structure, the inward acceleration field on its core (neutron’s surface) makes the proton an ultra stable particle. Similar to the electron, the proton also has its maximum velocity field confined within the diametrical plane at right angles to the axis of rotation. From (4.2), for an irrotational vortex: ur is constant. Therefore, the maximum tangential velocity (u_p) of space at the surface of the proton’s core in the diametrical plane transverse to the

¹ Universal principles of Space and Matter – A call for Conceptual Reorientation

axis of rotation is found from: $u_p r_n = c r_e$, where c is the tangential velocity at the interface of electron of radius r_e . From this:

$$u_p = \frac{c r_e}{r_n} = \frac{c r_e}{12 r_e} = \frac{c}{12} \quad (4.29)$$

The electric charge of proton due to u_p is computed from the relationship similar to the charge equation (4.4):

$$q_p = \left(\frac{\pi}{4}\right) 4\pi r_n^2 u_p = \left(\frac{\pi}{4}\right) 4\pi (12 r_e)^2 \frac{c}{12} = 12\pi^2 r_e^2 c \quad (4.30)$$

which is 12 times the electron charge. The reason why a hydrogen atom (Fig.11), which has a proton and an electron, shows neutrality, is due to cancellation of their magnetic moments as shown below. The orbiting electron is located at a distance reducing its velocity field to the same value as at the surface of the proton core: $c r_e = (c/12) r$, where r is the distance of the electron center from the surface of the neutron; from this $r = 12 r_e$, and is equal to r_n from (4.28). Thus, the radius of the electron orbit is $2r_n$. The magnetic moment of the orbital electron is due to its intrinsic spin (4.16) and also its orbital velocity v_{orb} . The total of the magnetic moments is:

$$\mu_e = \frac{(3/4)q_e c r_e + q_e V_{orb} (12 r_e + 12 r_e)}{2} = q_e r_e \left[\left(\frac{3c}{4}\right) + 12 V_{orb} \right] \quad (4.31)$$

The intrinsic magnetic moment of the proton, from an expression similar to the

electron (4.16) is $\mu_p = (3/4)[q_p(c/12)12 r_e]$. Substituting, $q_p = 12 q_e$, from (4.30):

$$\mu_p = (3/4)[12 q_e (c/12)12 r_e] = 9 q_e c r_e \quad (4.32)$$

Equating the magnetic moment of the electron (31) with the magnetic moment of the proton (4.32), in order to achieve the electrical neutrality of hydrogen atom: $q_e r_e [(3c/4) + 12 v_{orb}] = 9 q_e c r_e$, which gives: $v_{orb} = 0.69c$. In the hydrogen atom, the radius of the electron orbit is $24 r_e$, that is, about 10^{-9} cm; and its orbital velocity is 69% of speed of light. With this high rotational speed, the orbital electron completes one orbit in a time duration of: $(2\pi)10^{-9} \text{cm} / (0.69)3 \times 10^{10} \text{cm/s}$, that is, 3×10^{-19} s, providing an outer shield to the hydrogen atom with its spinning interface that can not be penetrated.

The binding force provided by the velocity fields of the oppositely spinning vortices of the orbital electron and the proton maintain the assembly with no energy loss from the system since the vortices are formed in non-viscous space.

The nucleus of Hydrogen (a neutron within a proton vortex) has an inward acceleration field of strength: $(c/12)^2/12 r_e$, that is, $(1/12)^3 c^2/r_e$. This inward field, which is $(1/12)^3$ times less than the maximum possible field (c^2/r_e) on the interface of electron, makes it a highly stable particle as stated before. In a similar manner, two protons and two anti protons (with opposite direction relative to the proton vortex), enclosed within an overall space-vortex, can assemble an alpha particle, a helium nucleus. With several alpha particles assembled with four in each unit (similar to the assembly of primary units in the neutron structure), and enclosed within an overall vortex, all nuclei of atomic mass higher than helium can be built. This process requires that nuclei should have equal numbers of neu-

trons and protons, which, however, is not the case. For instance, the ratio of neutrons to protons in Uranium nucleus is 1.586. This leads to the conclusion that in addition to the alpha particles, neutrons are also *independently* present as required by the atomic masses of the nuclei. The emission of alpha particles from radioactive nuclei provides a solid proof of their existence within nuclei in an *independent* condition. The presence of electrons and positrons in nuclei are confirmed by beta particle radiation. For simplicity in the analysis of the stability of nuclear structure, we can assume that protons and neutrons exist independently in a dynamic assembly, and each proton exerts a repulsive force on the rest of the protons in the nucleus which is enclosed within an overall space-vortex. The space-vortex enclosing the nucleus creates an inward field acting on the nucleus and it has a maximum value in the diametrical plane at right angles to the axis of rotation of the nucleus; given by u_n^2/r_n where u_n is the tangential velocity of space at the nuclear surface in the diametrical plane, transverse to the axis of rotation, and r_n is the nuclear radius. Since from (4.2), u_n varies inversely as r_n , the *inward* acceleration field on the nucleus falls inversely as the cube of r_n . The *outward* electrical repulsive forces within the nucleus trying to disrupt its structure (due to the presence of protons) fall inversely as the square of r_n . Since the inward acceleration field falls faster, nuclei with more protons and a larger radius become radioactive. By equating the outward electrical force in the nucleus with the inward force it is concluded that *stable* nuclei with protons more than 100 cannot exist in nature. More details on the structure of atoms larger than hydrogen atom are given elsewhere¹.

¹ Universal Principles of Space and Matter -A Call for Conceptual Reorientation

Fig. 4.10

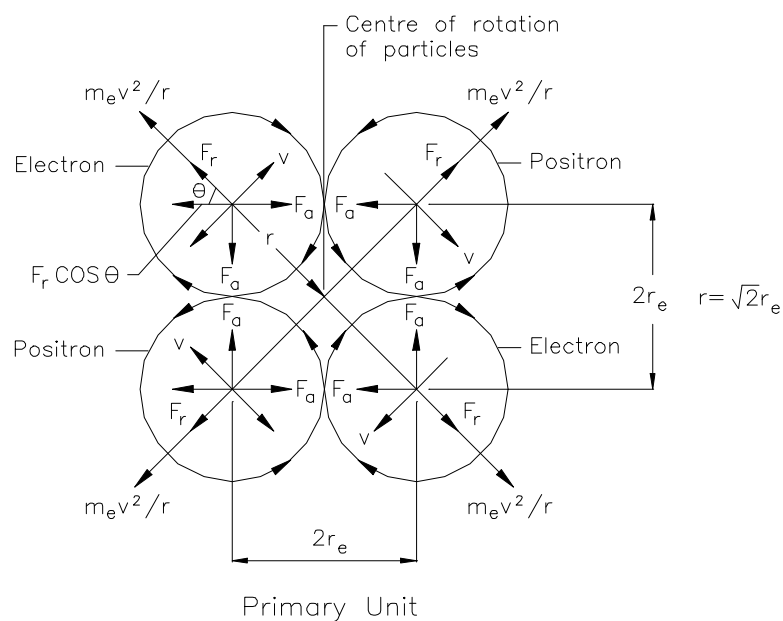
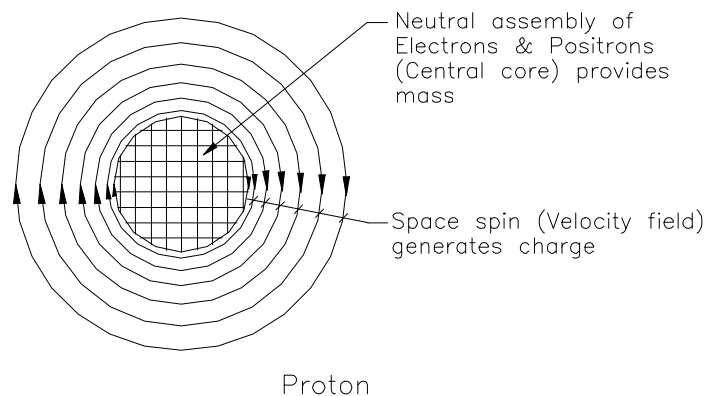

Fig. 4.9

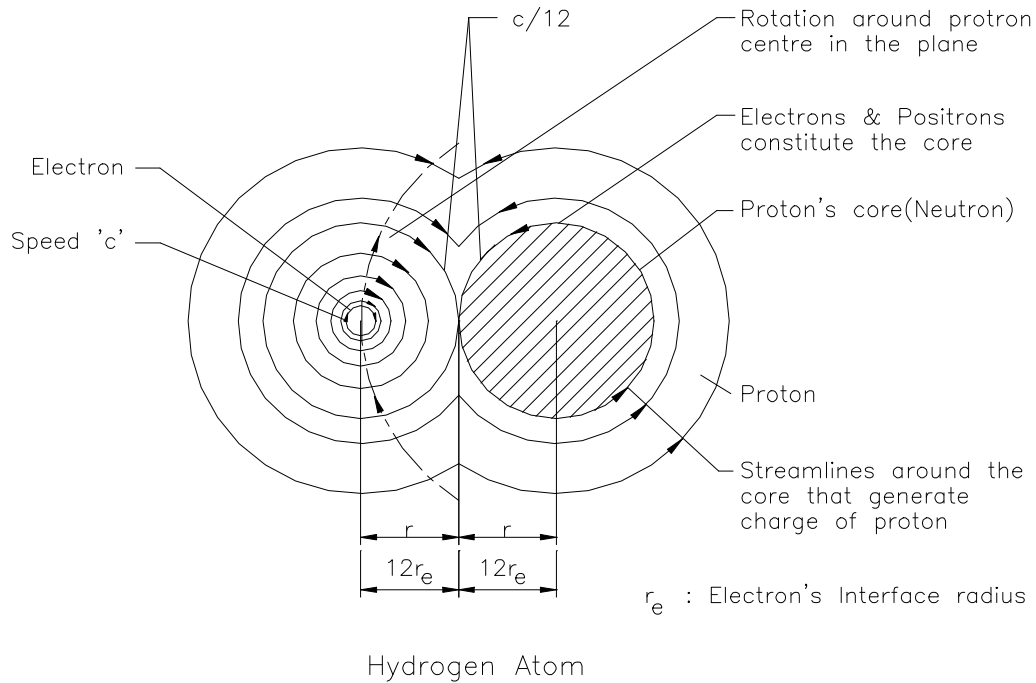

Fig. 4.11

4.22 Interaction of orbital electrons in an atom with a wave-pulse (shell) of light

With the nuclear structure described above, the nuclear radius of an average atom (120 times proton mass) is computed as: $r_n = 2.37 \times 10^{-9} \text{ cm}$. The maximum velocity field at the nuclear surface from (4.2) will be; $u_n = 5 \times 10^8 \text{ cm/s}$ in the atomic vortex around the nucleus, this velocity field will fall off inversely with distance to; $v = 1.2 \times 10^8 \text{ cm/s}$ at a radial distance of 10^{-8} cm , which is assumed to be the orbital radius of the outermost electron. The orbital electron in the space vortex will be subjected to an inward acceleration field; $a_f = v^2/\text{orbital radius} = (1.2 \times 10^8 \text{ cm/s})^2/10^{-8} \text{ cm} = 1.44 \times 10^{24} \text{ cm/s}^2$. Suppose a light shell of wavelength λ , and an acceleration-field a_l , across the wavelength (directed towards the source) meets the orbiting electron at an instant when both the above acceleration fields are in line. Since the direction of a_l is opposite to that of a_f , the two acceleration fields will nullify and the electron will be released from the vortex if: $a_l = a_f$. As stated earlier, $a_l = c^2/\lambda$. Substituting the values of the acceleration fields: $(3 \times 10^{10} \text{ cm/s})^2/\lambda = 1.44 \times 10^{24} \text{ cm/s}^2$, from which, $\lambda = 6.25 \times 10^{-4} \text{ cm}$, corresponding to a frequency of $0.48 \times 10^{14} \text{ cycles/s}$. (For metallic sodium, the threshold frequency for the photoelectric effect is about $5 \times 10^{14} \text{ sec}^{-1}$). The orbital electron, moving with velocity v , will be released with the kinetic energy that it *already* possesses:

$E = (1/2) m_e v^2 = (0.5 \times 10^{-28} \text{ gm}) (1.2 \times 10^8 \text{ cm/s})^2 = 7.2 \times 10^{-11} \text{ ergs}$. Experiments show that the kinetic energy of photoelectrons is about 8×10^{-11} ergs, very close to the above computed value! Considering the approximate nature of the assumption made on the electron's orbital radius and computation of the nuclear radius for an atom of average mass (Section 5.2), any better results are not expected. It is concluded that light (photons) does not impart energy to the photoelectron for its release. The kinetic energy of a released photoelectron is its own energy of motion in the space vortex of an atom. Light simply disturbs the stability of the forces under which the electron is stable in its orbit.

Chapter 5

UNIVERSAL GRAVITATION

5.0 Gravitational Interaction

Let us consider two stationary electrons, A and B, with their in-between distance R (Fig.5.1). Suppose the electrons, are not influenced by any external field except their own gravity fields – neglecting, for the present, their electrostatic field also. Due to superposition of their inward-fields in-between the particles, the fields around them are no more uniformly distributed. Consequently, the gravity fields in the outer regions of the particles exert inward-forces (F_a , F_b), pushing the particles closer. Now, consider the case when the two particles are created (they come into existence) at two different times. Let A be created first at t_0 . Its gravity field will be transmitted in space and cover the distance R at a time $t_0 + R/c$. It will continue to transmit further (spherically outward) at speed c relative to space. If, B is created later than t_0 , its gravity field will reach A later than the time, $t_0 + R/c$, and will gravitationally interact with A instantly, because A, having been created earlier, already possesses its gravity field on its interface. Thereafter, as both the particles now have their fields –starting from their interfaces and spread out, permanently, far in space – in contact with each other, they will have continuous gravitational attraction between them. We thus see that *if the instant of creation of bodies is not taken into account, then, to debate whether gravitational interaction between bodies is instantaneous or with time-delay is not a relevant issue*. That being the case, the Newtonian proposition that bodies (already existing) at a distance interact instantaneously and continuously, is right for gravitational interaction.

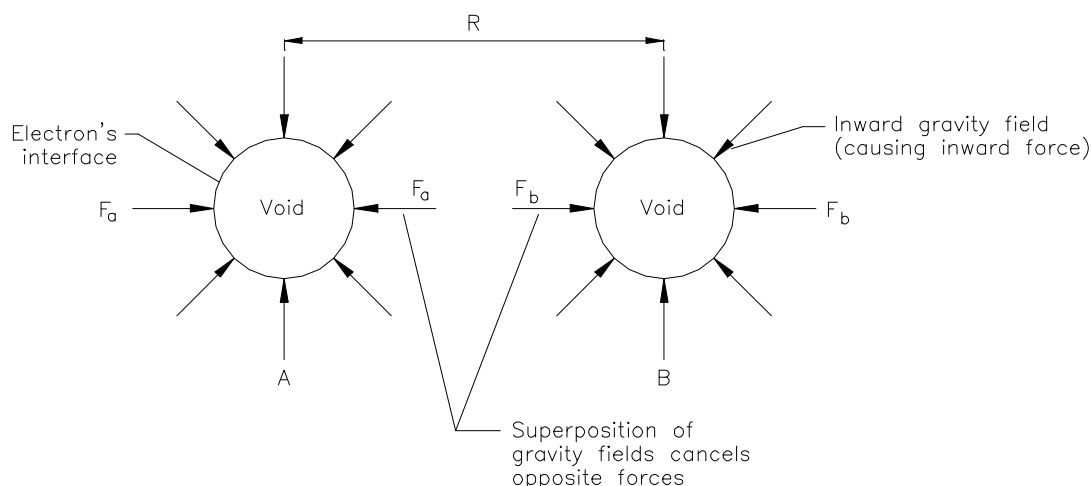

Fig. 5.1

But, this is not tenable as per relativistic physics, according to which: if we take the example of the force between two electrical charges, located at some distance apart, and give a slight movement to one of them, it takes some time for the influence (electromagnetic field) to reach the second charge due to the time required for transmission of the effect at the speed of light. During the period the influence transmits to interact with the second charge, it is argued that the momentum of the particles (charges) is not conserved. In order to conserve momentum at each moment, the field is ascribed with the property of momentum. This happens because the very process, which accounts for the property of mass to these particles, is yet to be discovered in contemporary physics. Ascribing mass and momentum that are material properties, to fields as well, is clearly a misconception. In Chapter 13, it is shown that space-circulation, in the central zone of the Sun, and also around the galactic center, reaches the limiting speed c , thereby leading to a continuous creation of electrons, positrons, and atoms (assembled with these particles). Even if half the electrons are annihilated, the remaining half will lead to creation of cosmic matter. This process of matter creation will increase the gravitational field within and beyond the solar system.

5.1 Gravitational Constant

The gravitational constant for the electron from (4.27) is

$$G_e = k / 4 \pi c \quad (5.3)$$

with the dimensions of, $1/ LT$, because, k has the dimension of $1/T^2$, which is $1/s^2$ in the CGS system of unit. Substituting the value of c in (5.3), the gravitational constant for the electron

$$G_e = 1 / 4\pi (3 \times 10^{10} \text{ cm / s}) s^2 = 2.65 \times 10^{-12} / \text{cm s}. \quad (5.4)$$

The gravitational constant, experimentally determined, is: $G = 6.67 \times 10^{-8} \text{ g}^{-1} \text{ cm}^3 \text{ s}^{-2}$.

From (4.12), converting gram into cm^4/s ,

$$G = (6.67 \times 10^{-8}) / (8.6 \times 10^6 \text{ cm}^4/\text{s})^{-1} \text{cm}^3 \text{ s}^{-2} = 0.78 \times 10^{-14} / \text{cm s}. \quad (5.5)$$

The gravitational constant for the electron (5.4) is about 339 times larger than the experimental value (5.5) of G . This is because the experimental determination of G involves attraction between atoms, rather than between free electrons. The theoretical value of G , for atoms, can be obtained as follows.

Consider the gravitational field of electron at its interface (4.27) where, $r = r_e$.

$$g = (k/4\pi c) m_e / r_e^2 = G_e m_e / r_e^2. \quad (5.6)$$

From the mass equation (4.6) that expresses m_e in terms of r_e and c , (5.6) becomes

$$g = G_e (4\pi/3) r_e^3 c / r_e^2 = G_e (4\pi c/3) r_e. \quad (5.7)$$

From above, it is seen that G_e is inversely proportional to the interface-radius.

The nuclei of atoms, with dynamically stable spherical assemblies of electrons, have their radii larger than the electron radius. Applying the proportionality between G_e and r_e given by (5.7) for the electron, and also between the gravitational constant G and the nuclear radius of an atom, the theoretical value of G has been approximately obtained below.

Consider the atom of lead, which was also the substance used by Cavendish in his famous experiment to determine the value of G . The atom of lead is 202.7 times the proton mass of 1.672×10^{-24} gm, that is, 3.39×10^{-22} g, or, $3.39 \times 10^{-22} \times (8.4 \times 10^6 \text{ cm}^4 / \text{s})$, which is $2.84 \times 10^{-15} \text{ cm}^4 / \text{s}$. If the radius of this nucleus is r_n , then from the mass-equation (4.6)

$$(4\pi/3) r_n^3 = 2.84 \times 10^{-15} \text{ cm}^4/\text{s} / 3 \times 10^{10} \text{ cm/s},$$

$$\text{or} \quad r_n = 2.83 \times 10^{-9} \text{ cm}. \quad (5.8)$$

As stated above, similar to the electron, assuming the gravitational constant's proportionality in the inverse ratio of the nuclear radius,

$$G = (r_e / r_n) G_e = (4 \times 10^{-11} \text{ cm} / 2.83 \times 10^{-9} \text{ cm}) 2.65 \times 10^{-12} / \text{cm s} = 3.75 \times 10^{-14} / \text{cm s}. \quad (5.9)$$

The theoretically determined value of G , computed above, is 4.8 times larger than the experimentally determined value (5.5). The reason for this wide difference is analyzed further. It can, however, be concluded that *the gravitational constant for the fundamental particle of matter is inversely proportional to the speed of light (4.27). Also, the experimentally determined value of G should be greater for the lighter nuclei with smaller radii compared to the heavier ones.*

5.2 Inter relationship between light and gravity

Consider an electron oscillating about its center with a displacement dR , as shown in Fig.5.2. Let us consider only its gravitational field. At a point P at a distance R from the

electron center, where the gravitational field from (5.7) is $G_e m_e / R^2$, the gravitational potential energy is

$$U = G_e m_e^2 / R. \quad (5.10)$$

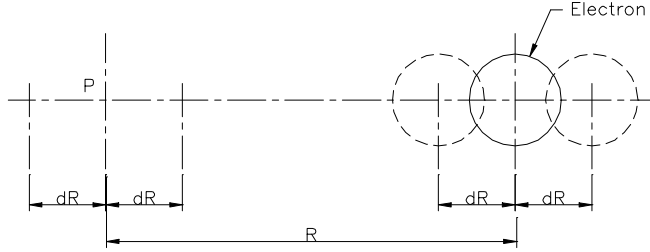

Figure 5.2

The oscillations of the electron change the distance R of the point P by dR on its either side, due to which the gravitational potential U undergoes cyclic changes in its magnitude. The effect of this time-varying change (increase and decrease) of potential starts from the interface of the electron, and transmits out at speed c , thus producing a light-effect at P when it reaches there. This process of a “time varying potential” at a point in space, resultant due to the oscillations of electrons or atoms (see, Chapter 10) produces light. From (5.10),

$$dU / dR = - G_e m_e^2 / R^2 = - G_e m_e (m_e) / R^2. \quad (5.11)$$

Expressing m_e (in bracket) in terms of r_e and c from (4.6); substituting from (5.7): $k / 4 \pi c$ for G_e , and $R = r_e$ to determine the potential gradient at the interface of the electron,

$$dU / dR = -(k / 4 \pi c) m_e [(4\pi/3) r_e^3 c] / r_e^2 = -k (m_e c r_e) / 3c.$$

Or
$$dU / (dR/c) = k (m_e c r_e) / 3. \quad (5.12)$$

The quantity, dR/c , is the time-duration dt for transmission of the potential changes across dR . Multiplying and dividing the right hand side of (5.12) by $4/5$,

$$dU / dt = k (4/5) m_e c r_e (5/4)/3. \quad (5.13)$$

The quantity, $(4/5) m_e c r_e$, is the angular momentum (L) of the electron (4.15) derived earlier; its numerical value is found by substituting the known values of m_e , c , and r_e :

$$L = (4/5)(9.108 \times 10^{-28} (3 \times 10^{10} \text{ cm/s}) 4 \times 10^{-11} \text{ cm}) = 0.88 \times 10^{-27} \text{ erg s.}$$

The dimensions of L are the same as that of the Planck's constant, The numerical value of L for the electron, calculated above, is about 7.5 times smaller than the Planck's constant: $h = 6.62 \times 10^{-27}$ erg s. However, Planck's constant was determined in experiment with the thermal radiation produced due to atomic vibration, and not with the oscillation of free electron¹ as being analyzed here. Therefore, too close a numerical agreement of the values of L and h are not expected. Under these considerations, it is defined that at a point in space, "time varying gravitational potential" due to oscillation of an electron, produces energy proportional to the Planck constant. Substituting: $h = (4/5) m_e c r_e$, in (5.13), gives the basic equation on the inter relationship between the gravity and light:

$$dU/dt = (5k/12) h. \quad (5.14)$$

5.2 Planck's constant in thermal radiation

The basic-relationship (5.14) can be checked, by analyzing the oscillations of a single atom. Let us choose an atom of an average atomic weight, say 120 times the mass of a proton. Its mass is:

$$m_a = 120(1.67 \times 10^{-24} \text{ g}) = 2 \times 10^{-22} \text{ g}$$

which from (4.12) becomes

$$m_a = 2 \times 10^{-22} (8.6 \times 10^6 \text{ cm}^4 / \text{s}) = 1.72 \times 10^{-15} \text{ cm}^4 / \text{s}.$$

Volume of this nucleus is $V_n = (4\pi/3) r_n^3$, where r_n is the nuclear radius of the atom.

The mass-equation (4.6), though applicable, in a strict sense, only to the electron structure, can also be used for the nuclear structure because the density of distribution of electrons and positrons in all nuclei is the maximum. Therefore, from above

$$V_n = (4\pi/3) r_n^3 = m_a / c,$$

and
$$r_n = (3 m_a / 4\pi c)^{1/3}.$$

Substituting the value of m_a derived earlier,

$$r_n = [3 \times 1.72 \times 10^{-15} \text{ cm}^4 / \text{s} / 4\pi \times 3 \times 10^{10}]^{1/3} = 2.39 \times 10^{-9} \text{ cm}. \quad (5.15)$$

The gravitational potential energy at the surface of the nucleus

$$U = G m_a^2 / r_n \quad (5.16)$$

¹ It is shown further that rotation of electron in atomic orbit is not the basic cause of radiation production

Substituting the presently known value of G , and of m_a and r_n computed above,

$$U = 6.67 \times 10^{-8} \text{ g}^{-1} \text{ cm}^3 \text{ s}^{-2} (2 \times 10^{22} \text{ g})^2 / 2.37 \times 10^{-9} \text{ cm} = 11.156 \times 10^{-43} \text{ erg.} \quad \text{--- (5.17)}$$

Supposing that the average period of oscillation of an atom is 10^{-15} s, the duration (dt) of the change in the gravitational potential at the nuclear surface is $(1/2) 10^{-15}$ s.

Substituting in (5.14) the above value of dt and of U computed in (5.17)

$$dU / dt = 11.156 \times 10^{-43} \text{ erg} / (1/2) 10^{-15} \text{ s} = (5 / 12 \text{ s}^2) h.$$

$$\text{From above, } h = 5.36 \times 10^{-27} \text{ erg s.} \quad (5.18)$$

The above result, theoretically obtained, compares close to the experimental value (6.62×10^{-27} erg s) of h, thus proving that the *light-effect at a point in space is produced due to the time-varying gravitational potential at that point.*

5.3 Electromagnetic energy

A free electron is not a force-free particle, because, even when imagined to be free from external influences, it has inwardly directed gravitational and acceleration fields. These fields which can be named as “structural fields” can keep the electron’s interface stationary due to their symmetrical distribution (axi-symmetric). However, when interacted with the fields of other matter, the electrons and all particles/atoms –constituted by the electrons and positrons –are, invariably, in motion/oscillations around their centers. Such vibrations, as discussed above, produce in space pulsations of potentials associated with the vibrating particles, thus producing light effect without any reduction in the structural energy of the particles. Electromagnetic energy (light), at a point in space, is the effect from the *already-existing potentials* at that point. In this sense, it is not the basic form of energy, because, but for the gravitational potential created by the atoms (externally, neutral), light-effect will not exist.

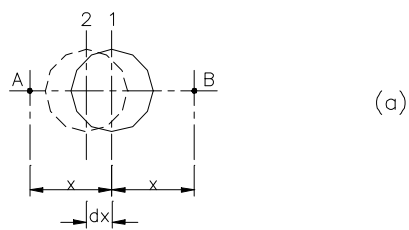
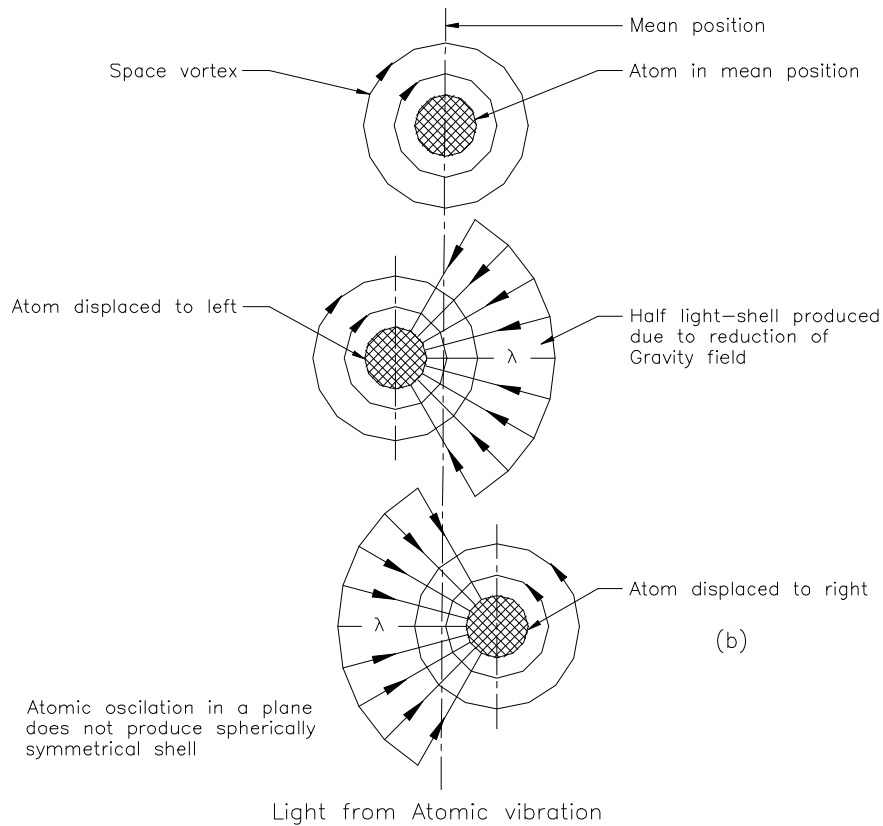

G : Gravitational constant
 m_a : Atomic mass

- 1) When Atomic centre is at position 1, inward gravity field at 'A' & 'B' are Gm_a/x^2
- 2) When atom moves to position 2, inward gravity field at 'A', will be $Gm_a/(x-dx)^2$, & at 'B', $Gm_a/(x+dx)^2$. The change in fields will take place after a time x/c , from the instant atom moves towards 'A'. The reduction of gravity field at 'B', will result as light effect at 'B'.

Fig. 5.3

Chapter 6

SPACE INHERENT WITH MOTION

6.0 Cosmic vortices

The space vortex structure of the electron repeats in identical patterns in the structures of the planets, stars and galaxies too. There are space vortices enclosing individually all the cosmic bodies with axial rotation. These vortex circulations perform several functions like: creating surface gravity, causing axial rotation, producing electrical charge on the surface of the cosmic bodies, and also producing electrical charge and electrical forces of attractive and repulsive nature, between them. Another striking similarity between the fundamental matter and the planets/stars/galaxies is in their material structure. The discrete (independent) volumes of the voids in the structure of the electrons and positrons that constitute nuclei / atoms, and assemble into cosmic bodies, when summed up, amount to a large volume of void, in proportion to the mass of the cosmic bodies. This volume of void is enclosed within a space vortex; just as a single electron's central void is enclosed within a space vortex.

High velocity fields in the vortices around cosmic bodies cause their axial rotation perpetually due to zero viscosity of space. The orbital-motion of the satellites, planets and stars, around their respective primaries, are also caused due to the velocity fields of cosmic vortices. Taking example of the solar system, it is explained below that the orderly orbital motion of the planets and satellites is the result of regulation by the velocity fields in the solar space vortex.

6.1 Solar Space Vortex

The solar system consisting of the satellites, planets, and the Sun is a large space-vortex with the Sun at its center. Fig. 6.1 shows, partially, the solar space vortex, in the equatorial plane of the Sun, and at right angles to the axis of rotation. This forms the planetary plane. The velocity field of the space vortex surrounding the Earth, rotates it axially, whereas, the planet Mercury has no vortex around, for its axial rotation. For simplicity of the sketch, only two planets—mercury and earth—are shown. The other planets too have their respective space vortices within which the satellites are located. The velocity field of the solar vortex carries the planets and, similarly, the satellites are moved by the vortices of their respective planets. Neither the planets, nor the satellites have, normally, relative motion with respect to the medium of space in their immediate vicinity and, hence, their orbital motion does not develop centrifugal force on them. In simple words, the planets are *carried along* by the streamlines of the solar vortex, whereas, the satellites follow, generally, the streamlines of the planetary vortices.

When looked at from the top of the planetary plane, the Sun and the planets rotate anti clockwise (Fig. 6.1). From this it is inferred that their space vortices, that impart angular momentum

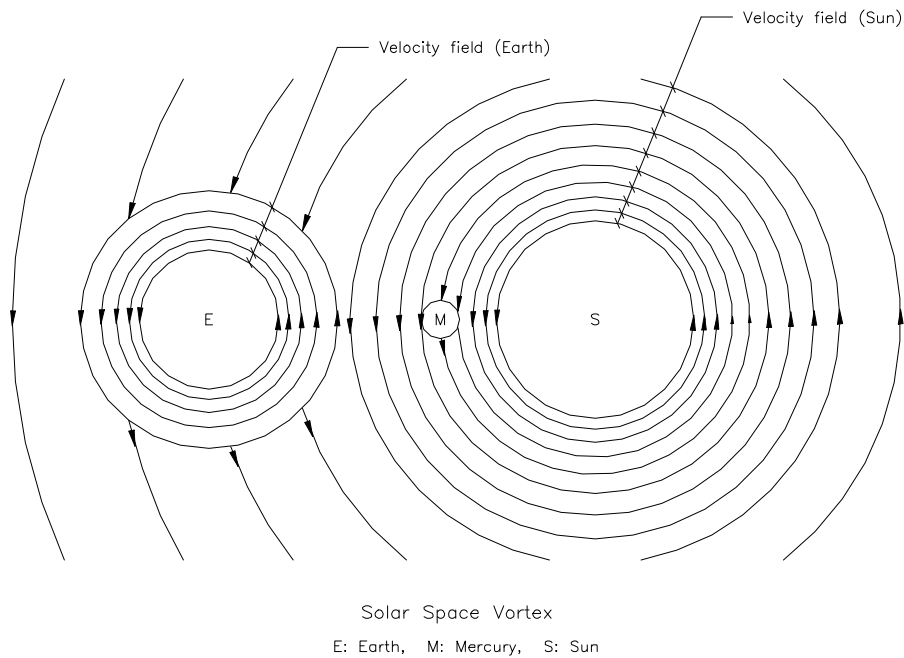

Fig. 6.1

to them, also have anti clockwise rotation. From Fig. 4.4, it is seen that space vortices with opposite rotations attract each other electrically. It, therefore, follows that had there been a planet with axial rotation opposite to the Sun, it will fall on to it under the electrical force of attraction. The repulsive electrical force between the Sun and the planets is calculated further. However, it can be inferred here that, by and large, *in all the star systems in the universe including our own solar system, the axial rotations of the stars and their associated planets have to be in the same direction for the stability of these systems.*

6.2 Velocity Field distribution in solar space vortex

Refer Fig.6.2 showing the Sun's side view (taken spherical for simplicity) with the radius R_s , and the Earth in the planetary plane, which is transverse to the axis of the Sun's rotation. The velocity fields in the vortices around the Sun and the Earth are shown as circular

streamlines. The planetary plane has been taken disc-shaped, with its thickness equal to equal to the diameter of the Sun.

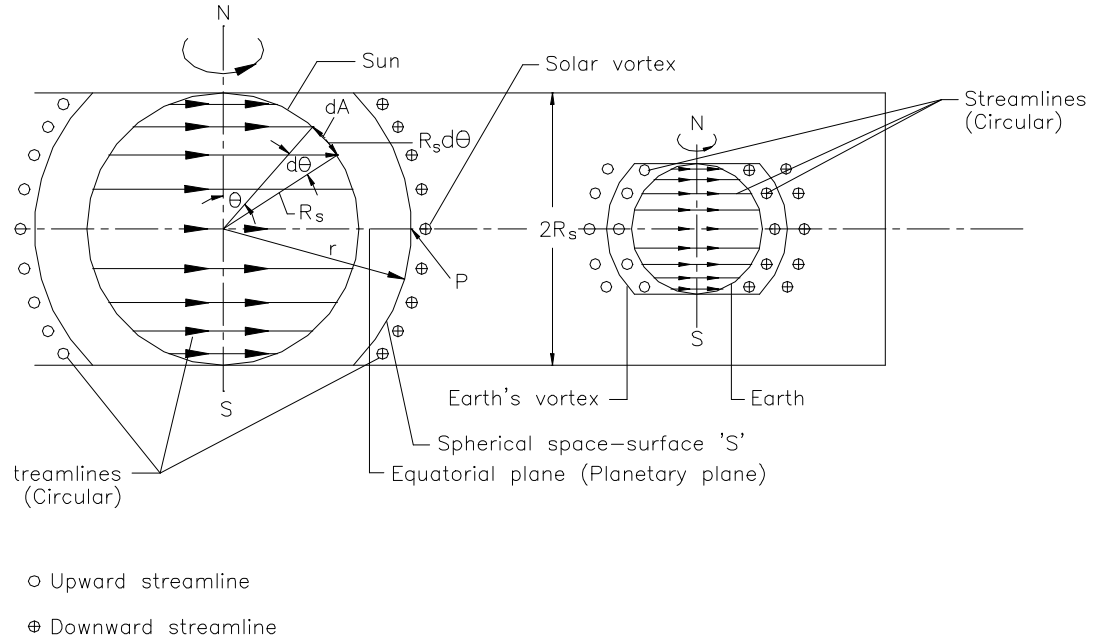

Fig. 6.2 Solar Space Vortex

Consider an elemental area dA on the rotating surface of the Sun such that

$$dA = 2\pi R_s \sin \theta R_s d\theta. \quad (6.1)$$

The period of axial rotation of the Sun varies from 26 days at the equator to 37 days at the poles. If the average angular velocity of rotation be ω_s , then the tangential velocity at the elemental surface will be

$$V_s = \omega_s R_s \sin \theta \quad (6.2)$$

where V_s is also the velocity field of space in the immediate vicinity of the surface, and tangential to the elemental area dA .

Due to V_s acting on each point of dA , there will be an *inward*¹ acceleration a_s such that

$$a_s = V_s^2 / R_s \sin \theta. \quad (6.3)$$

¹ The nuclei of atoms constituting the Sun have independent electrons in their structure. Similar to the electron which, due to central void, has inward acceleration field on its interface, the Sun and the planets too have inward acceleration fields on their surfaces.

From (6.1) and (6.3), the product, $dA a_s$, is

$$d\phi_s = (2\pi R_s^2 \sin \theta d\theta) [(\omega_s R_s \sin \theta)^2 / R_s \sin \theta]$$

where ϕ_s is defined as “space acceleration flux”.

Integrating, varying θ from 0 to π

$$\phi_s = 2\pi R_s (\omega R_s)^2 \int \sin^2 \theta d\theta = \pi^2 R_s (\omega R_s)^2. \quad (6.4)$$

From (6.2), for $\theta = \pi / 2$, V_s has a maximum value on the Sun’s surface in the equatorial (planetary) plane of the Sun: $V_{sm} = \omega R_s$. Substituting this relationship in (6.4)

$$\phi_s = \pi^2 (V_{sm})^2 R_s. \quad (6.5)$$

Due to zero-viscosity and continuity of the medium of space, the acceleration flux ϕ_s remains constant at every spherical space-surface, concentric with the Sun’s center. Fig.6.2 shows a spherical space surface S. From (6.5)

$$(V_{sm})^2 R_s = \phi_s / \pi^2 = \text{constant}$$

Or,
$$V_{sm} \propto 1 / \sqrt{R_s} \quad (6.6)$$

From above it is seen that the tangential velocity V_{sm} at the Sun’s surface, and also of the space-point in contact with the Sun’s surface (stated before), falls inversely as the square root of the distance from the Sun’s center (due to above-mentioned constancy of the acceleration flux). If, in the solar vortex, V_t is the tangential velocity-field on the circumferential points of a circle of radius r in the planetary plane (Sun’s equatorial plane) concentric with the Sun; then from (6.6)

$$V_t \propto 1 / \sqrt{r} = k / \sqrt{r} \quad (6.7)$$

where k is a constant pertaining to the solar space-vortex.

It was stated in Section 6.1 that the velocity fields of the solar space vortex move the planets. Therefore, from (6.7) it follows that the orbital speed of the planets should be inversely proportional to the square root of the distance from the Sun’s center which, in fact, is as per Kepler’s third law:

$$T^2 \propto r^3 \quad (6.8)$$

where T is the period of any of the planets of the solar system, and r is its distance from the Sun’s center. Substituting in the above equation, $T = 2\pi r / V$, where V is the orbital velocity of the planet

$$(2\pi r / V)^2 \propto r^3$$

$$\text{Or } V \propto 1 / \sqrt{r} \quad (6.9)$$

A theoretical proof to the third law of Kepler (6.8), which is supported by astronomical measurements, is provided by deriving this law with the concept of “space acceleration field” acting on the surface of the Sun in the solar space vortex.

6.3 Free fall acceleration on the Sun’s surface

Let us consider the innermost planet of the solar system, Mercury, which has an orbital speed of 47.9 km/s, and the mean distance from the Sun’s center: 57.9×10^6 km. With substitution in (6.7),

$$k = 47.9 \times 10^3 \text{ m/s } (57.9 \times 10^9 \text{ m})^{1/2} = 11.52 \times 10^9 \text{ m}^{3/2}/\text{s}. \quad (6.10)$$

The maximum tangential velocity of space (V_{sm}) on the periphery of the Sun in the planetary plane is now found from (6.7) by substituting the value of k and the mean- radius of the Sun:

$$V_{sm} = (11.52 \times 10^9 \text{ m}^{3/2} / \text{s}) / (6.96 \times 10^8 \text{ m})^{1/2} = 4.367 \times 10^5 \text{ m/s}. \quad (6.11)$$

This tangential velocity-field will create on the surface of the Sun, and in the planetary plane, an *inward space acceleration field* of maximum value:

$$a_{fm} = (4.367 \times 10^5 \text{ m/s})^2 / 6.96 \times 10^8 \text{ m} = 274 \text{ m/s}^2. \quad (6.12)$$

As per classical mechanics, the *surface gravity* of the Sun is also 274 m/s^2 , which happens to be exactly the same as the space acceleration field derived above. Further, as per Newton’s gravitational theory, which is presently accepted, surface gravity on the Sun is due to its mass; and free-fall acceleration on its surface is due to gravitational attraction. Quite different from these conclusions of classical physics, it is the solar space-vortex creating space-circulation around the Sun that, in turn, produces inward acceleration field for the free-fall of bodies on the Sun’s surface. The above derivation of the free-fall acceleration (6.12) has not made use of any mass-property of the Sun or the planet Mercury. Therefore, *the “free-fall acceleration” on the Sun’s surface is concluded to be caused, primarily, by an inward acceleration field in the surrounding solar space vortex, creating force on bodies to make them fall downwards on its surface.*

6.4 Free fall Acceleration on the Earth’s surface

Refer Fig.6.3. The Earth is enclosed within a space vortex that, as stated before, imparts axial rotation to it; and the Moon cannot be supposed to have space vortex around it, since it does not possess axial rotation. The Earth along with the Moon is carried by the solar space vortex in an elliptical (assumed circular for simplicity) orbit.

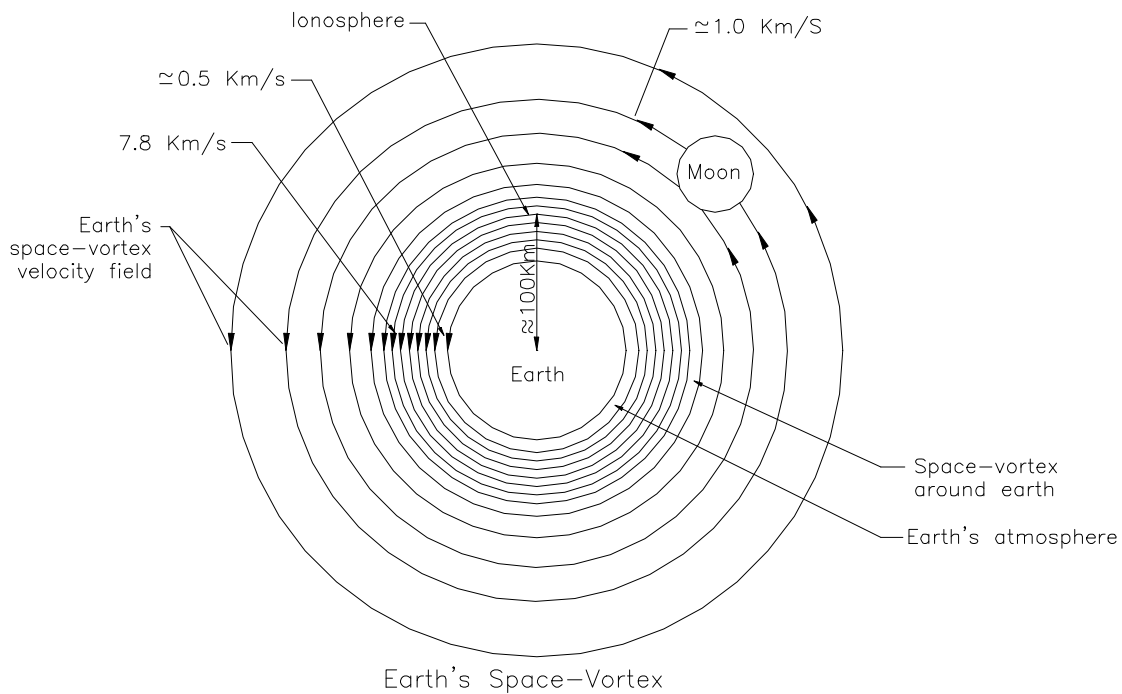

Fig. 6.3

The velocity field in the Earth vortex carries the Moon around the Earth with an orbital speed of 1017 m/s (derived from the period of 27.3 days; radius of the orbit: 3.82×10^5 km). From (6.7)

$$V_m \propto 1 / \sqrt{r} = k_e / \sqrt{r} \quad (6.13)$$

where V_m is the orbital velocity of the Moon; r is its distance from the Earth center; and k_e is a constant pertaining to the Earth's space-vortex. Substituting the values of V_m and the radial distance of the Moon's orbit, given earlier,

$$k_e = (1017 \text{ m/s}) \times (3.82 \times 10^8 \text{ m})^{1/2} = 1.987 \times 10^7 \text{ m}^{3/2} / \text{s}. \quad (6.14)$$

Substituting the values of k_e and r in (6.13), which is the known radius of the Earth, the maximum tangential velocity of space in the equatorial plane and in close vicinity of the Earth surface, is determined as:

$$V_t = (1.987 \times 10^7 \text{ cm}^{3/2} / \text{s}) / (6.37 \times 10^6 \text{ m})^{1/2} = 7.8 \times 10^3 \text{ m/s.} \quad (6.15)$$

There exists a space-circulation at 7.8 km/s around¹ the Earth's surface in its equatorial plane that imparts axial rotation to it and also develops an inward acceleration field which is:

$$a_e = V_t^2 / R_e = (7.8 \text{ km/s})^2 / 6370 \text{ km} = 9.55 \text{ m} / \text{s}^2. \quad (6.16)$$

where R_e is the radius of the Earth. The inward acceleration field, derived above, is seen to be so close to the presently accepted surface gravity of the Earth: 9.81 m/s^2 , obtained from experimental measurements.

The proof on the real existence of space vortices around the Earth and the Sun lies in the above derivations of free-fall accelerations on the surfaces of these cosmic bodies.

Free-fall acceleration² for other planets, calculated similarly, is given in Appendix, A3, Table 1.

6.4 Free fall acceleration on the core of galaxy

In our galaxy, the solar system exists at a distance of about $2.62 \times 10^{22} \text{ cm}$ from the center of the galaxy, revolving around it at the speed of 220 km/s. Assuming that similar to the velocity field distribution in the solar vortex, in the galactic vortex too, the space-circulation (in the diametrical plane at right angles to the axis) falls inversely as the square root of the distance from the center of the galaxy

$$v = k_g / \sqrt{r} \quad (6.17)$$

where k_g is a constant, and r is the distance from the galactic center. Substituting the values of v and r as given above in (6.17), we get

$$k_g = v \sqrt{r} = (220 \times 10^5 \text{ cm/s}) (2.62 \times 10^{22} \text{ cm})^{1/2} = 3.56 \times 10^{18} \text{ cm}^{3/2} / \text{s.} \quad (6.18)$$

From (6.17) and (6.18), the distance R_g at which the space circulation in the galactic vortex reaches the speed of light is:

¹ It is shown later that space circulation at 7.8 km/s takes place at a height around the ionosphere.

² Marco Todeschini, Desisive Experiments in Modern Physics (Theatine Academy of Sciences, 6. Piazza Umberto 1-Chieti, Italy) has also calculated Earth's gravity considering a stream of fluid space around the Earth. He postulates fluid-ether with a very small density, unlike the mass-less space in SVT.

$$R_g = [(3.56 \times 10^{18} \text{ cm}^{3/2}/\text{s}) / (3 \times 10^{10} \text{ cm/s})]^2 = 1.408 \times 10^{16} \text{ cm} \quad (6.19)$$

which is about 203000 times more than the solar radius.

$$\begin{aligned} \text{Free fall acceleration at the surface of the galactic core} &= c^2 / R_g \\ &= (3 \times 10^{10})^2 / (1.408 \times 10^{16} \text{ cm}) = 6.392 \times 10^4 \text{ cm} / \text{s}^2 = 639.2 \text{ m} / \text{s}^2, \\ &\text{which is 2.33 times the free fall acceleration on the Sun's surface.} \end{aligned}$$

6.5 Genesis of the Solar Wind

As per recorded data on the solar wind close to the surface of the Sun, the wind velocity varied from a minimum of about 380 km/s to the maximum of about 500 km/s, giving an average of 440 km/s [<http://soho.nascom.nasa.gov/> ; 48 hours of solar wind data on 10 July 2002]. While the Sun rotates axially at a peripheral speed of about 2 km/s at the equator in the plane at right angles to its axis, the reason for so high a wind velocity is briefly explained below.

From (6.11), maximum velocity field at the solar surface is 436.7 km / s. This shows that in the near hood of the Sun's surface, its gaseous matter will be subjected to a maximum average velocity of 436.7 km / s, due to fluid-space circulation around the sun in the solar space vortex. The above computed value is so very close to the recorded data (440 km / s) mentioned above.

It is most unlikely, if not impossible, that through any other contemporary physical theories so accurate quantitative results and physical explanations revealing the genesis of the solar wind can be had.

Chapter 7

ELECTRICAL REPULSIVE FORCES BETWEEN COSMIC BODIES

7.0 Repulsive electrical forces between the sun and the planets

Similar to the structure of the electron (Fig. 4.2) in which the spherical interface surrounded by a space vortex, produces electric charge effect; the Sun and the planets (with axial rotation) too, possessing space vortices enclosing them, are charged cosmic bodies. Their electric charges will be directly proportional to the product of their respective surfaces and the tangential velocity of rotation of the material surface in the equatorial plane, as per the relationships in the basic charge-equation of electron (4.4). [Here is another example of uniformity in repetition of nature's design and the governing laws, applicable in sub micro as well as macrocosmic phenomena.] The solar charge is calculated as

$$Q_s = (\pi / 4) (\text{solar surface}) V_{sm} \quad (7.1)$$

where V_{sm} is the maximum tangential velocity of the Sun's surface in the equatorial (planetary) plane.

$$Q_s = (\pi / 4) 4\pi (6.96 \times 10^{10})^2 \times (1.945 \times 10^5 \text{ cm/s}) = 0.928 \times 10^{28} \text{ esu} \quad (7.2)$$

where, from (4.5), $\text{esu} = \text{cm}^3/\text{s}$, in CGSE system. Presently accepted value of the solar charge¹ is 10^{28} esu , which is extremely close to the above derivation.

Similarly, the electric charge of the Earth, due to its axial rotation, is proportional to the product of the surface and its tangential velocity in the equatorial plane:

$$Q_e = (\pi / 4) 4\pi (6.37 \times 10^8 \text{ cm})^2 (0.464 \times 10^5) = 1.85 \times 10^{23} \text{ esu}. \quad (7.3)$$

The electric charge of the Sun and the planets is tabulated in (see Appendix, A3).

It is significant to note that the Sun and the planets have the same rotational direction; which means that their charges have the same sign and, therefore, produce repulsive forces among them. As already stated (Section 6.1), it can be concluded that *stable systems of stars and their associated planets will have the same direction of axial rotations universally.*

Using (7.2) and (7.3), Coulomb's force between the sun and the Earth is calculated:

$$F_e = (c/4\pi) Q_s Q_e / r^2 \quad (7.4)$$

where r is the distance between them. Substituting the values from (7.2) and (7.3),

$$F_e = [(3 \times 10^{10} \text{ cm/s})/4\pi](0.928 \times 10^{28} \text{ cm}^3/\text{s})(1.85 \times 10^{23} \text{ cm}^3/\text{s}) / (1.5 \times 10^{13} \text{ cm})^2$$

where, from (4.5), $\text{cm}^3/\text{s} = \text{esu}$ or CGSE unit.

$$F_e = 1.822 \times 10^{34} (\text{cm}^4/\text{s}) \text{ cm/s}^2.$$

Substituting from (4.12), $\text{gram} = 8.6 \times 10^6 \text{ cm}^4/\text{s}$

$$F_e = 2.12 \times 10^{27} \text{ dyne.} \quad (7.5)$$

It is seen that the Earth in its orbit is subjected to an electrical repulsive force from the sun, rather than a centrifugal force as per classical celestial mechanics. And, such is the case with each planet (with axial rotation). A check can be made on the magnitude of F_e given by (7.5) by comparing it with the gravitational attraction between the Sun and the Earth, using Newton's equation and the values of the masses accepted today:

From Newton's equation on the gravitational force between the Sun and the Earth:

$$F = GM_s M_e / r^2 = (6.67 \times 10^{-8} \text{ cm}^3/\text{s}^2 \text{ g})(1.99 \times 10^{33} \text{ g})(5.98 \times 10^{27} \text{ g}) / (1.5 \times 10^{13} \text{ cm})^2.$$

$$F = 3.52 \times 10^{27} \text{ dyne.} \quad (7.6)$$

The gravitational force of attraction (7.6) is about 1.66 times more than the electrical repulsion (7.5), and can be taken to be approximately equal, but for the fact, that the mass of the Sun used here is 3.6 times less, whereas, the Earth's mass taken is about 12 times larger, as calculated in the following Section (see Appendix, A4). With these values, the repulsive force from the Sun will be about 3.4 times greater than the gravitational attractive force, leading to instability of the Earth's orbit. The above inequality of the two opposite forces casts doubt on Newtonian celestial mechanics. The stability of the planets taking into account electrical repulsive forces between the Sun and the planets is discussed ahead.

¹ The Morality of Nuclear Planning; H. C. Dudley (1978), Kronos Press, Glassboro, New Jersey 08208, USA.

Chapter 8

MASS OF COSMIC BODIES

8.0 Derivation of mass, using mass-equation

The assumption of empty-space in classical mechanics does not permit any inference that from the orbital rotation of the Moon, one can determine the actual rotation of the space around the Earth at the level of the ionosphere, as carried out in Chapter 6. This is because rotation of a void-space is certainly meaningless. To conclude, it is the presupposition that space is empty that has prevented, so far, the discovery of surface gravity through space dynamics. On scientific methods of research, an appreciation of the fact that the *physical aspects of a phenomenon are precursors to the quantitative findings* is needed.

If the mass-property of the Sun and the Earth (other planets too) is the basic cause for the gravitational attraction between them, then, taking clue from the mass-equation (4.6), the maximum velocity fields in their respective vortices, that determine free-fall accelerations (Chapter 6) should determine their mass also. The following computation of the mass of the Sun is independent of the surface gravity and also of the gravitational constant.

From (4.6) mass of the electron is proportional to its maximum velocity field c , and the volume of its single void. Similarly, for the Sun, multiplying and dividing the right hand side by c , we can write

$$M_s = V \times V_s = (V \times c) V_s/c \quad (8.1)$$

where V is the volume of the Sun; V_s : maximum velocity field in the Sun's vortex (6.11); M_s is the mass of the Sun.

Since, the volume of the Sun is composed of multiple electron's voids in the nuclei and atoms constituting the Sun, V_s is less than c and, therefore, M_s has been reduced by a factor V_s/c as shown in the above relation. Substituting the value of V and V_s in the above equation

$$\begin{aligned} M_s &= (4\pi/3) R_s^3 V_s = (4\pi/3) (6.96 \times 10^{10})^3 (4.367 \times 10^7 \text{ cm/s}) \\ &= 6.16 \times 10^{40} \text{ cm}^4/\text{s} = 6.16 \times 10^{40} (\text{g} / 8.6 \times 10^6) = 7.16 \times 10^{33} \text{ g} \end{aligned} \quad (8.2)$$

where from (4.12), $\text{gram} = 8.6 \times 10^6 \text{ cm}^4/\text{s}$.

Presently, the accepted mass of the Sun is:

$$M_s = 1.99 \times 10^{33} \text{ g} \quad (8.3)$$

which is reasonably¹ close to (8.2).

From calculations made on similar lines, mass of the planets in solar system are given in (see Appendix, A4). It is seen from Table 2 that while the Sun's mass comes out more than 3.6 times the presently accepted value, all other planets are lighter. In fact, the Earth's mass comes to about 12 times smaller than accepted today.

¹ The Essential Tension— The Function of Measurement in Modern Physical Science, Thomas S. Kuhn: “In the theoretical study of stellar magnitudes agreement to a multiplicative factor of ten is often taken to be reasonable”.

Chapter 9

ORBITAL STABILITY OF PLANETS

9.0 Mass of planets

Mass of the Earth can be determined by analyzing the stability of the Earth in its orbit, taken circular for ease of calculation. In Fig. 9.1 the velocity field of the Earth's vortex (b) has been superposed (c) with the solar-vortex velocity-field (a). Though there is no relative motion between the Earth and the surrounding space, yet a 'pressure' (action of the downward field) from the surrounding space, proportional to the resultant inward-acceleration-field produced by the above velocity fields, acts on the Earth's center (similar to a body, static on the Earth surface, being subjected to the inward free fall acceleration). As seen in the figure (c), the velocity field on the farther side of the Earth is increased, whereas, on the side nearer to the Sun has decreased. Due to this, the resultant acceleration field "a", acting inward on the Earth (which is moving along the orbit of the radius r) is given by

$$a = (29.8 \times 10^5 \text{ cm/s} + 7.8 \times 10^5 \text{ cm/s})^2 / r = (1.413 \times 10^{13} \text{ cm}^2 / \text{s}^2) / r. \quad (9.1)$$

The inward force F on the Earth (center) due to above acceleration, and in opposition to the electrical repulsive force (7.5) is

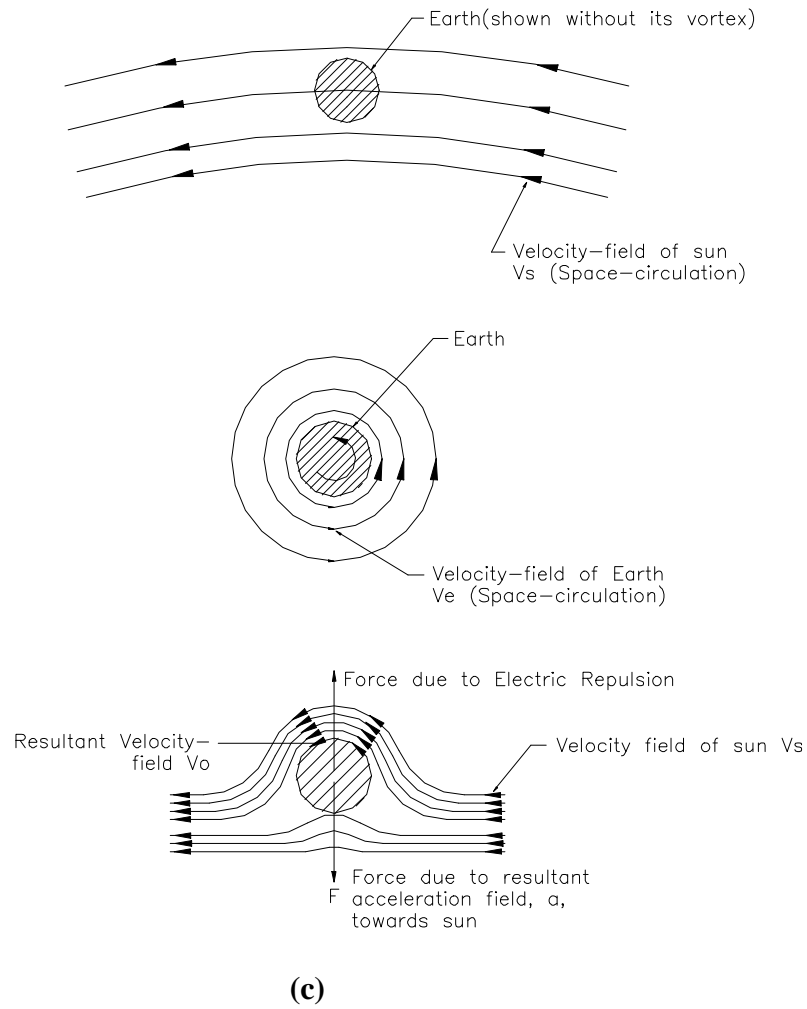
Fig. 9.1a**Fig 9.1**

$$F = M_e \times a = M_e (1.413 \times 10^{13} \text{ cm}^2/\text{s}^2) / r. \quad (9.2)$$

Equating the two opposing forces, acting radially on the Earth, from (7.5) and (9.2),

$$M_e (1.413 \times 10^{13} \text{ cm}^2/\text{s}^2) / r = 2.12 \times 10^{27} \text{ dyne.} \quad (9.3)$$

Substituting, $r = 150 \times 10^{11} \text{ cm}$ in (9.3)

$$M_e = 2.25 \times 10^{24} \text{ kg,}$$

which is 2.66 times less than the presently accepted value ($5.98 \times 10^{24} \text{ kg}$). The masses of other planets computed on similar basis are tabulated in (see Appendix, A3). It appears that the electrical repulsive forces from the Sun, Jupiter, Saturn and Neptune, acting some time in past at the time of their alignment (if such alignment is possible), have tilted Uranus such that its axis is inclined with respect to the planetary plane by almost at right angles. Due to this the velocity field of Uranus, causing its axial rotation, has not been taken into account for calculation of the inward force that opposes the electrical repulsion; though, in case of the Earth (9.1) and other planets, the resultant of velocity fields (due to axial as well as orbital rotations) has been taken for calculation of the inward acceleration field.

The mass of the planets in (see Appendix, A3) can be taken closer to the actual mass because these have been derived with orbital stability considerations, as compared to the values of mass in (see, Appendix, A 4). It is seen from (see, Appendix, A 3) that presently accepted masses of the planets are wide apart from the actual values that they should have. Saturn should be about two and half times heavier in mass; Jupiter's mass is close to the actual value; Mars is nearly twice as massive as presently considered; Both Uranus and Neptune should have nearly the same mass. The proof for the correctness of the mass of the planets, calculated from equations similar to (9.3), is provided in the following Section 9 by determining the orbital radii of the planets.

The forces on the Moon, Mercury and Venus¹ that do not possess space vortices around them, acting in their orbital motion are conjectured as follows.

In Fig. 6.3 the Moon, shown in the space-vortex of the Earth, is subjected to an inward acceleration, v_m^2/r , created by the velocity field of the vortex and, hence, a central force, $M_m v_m^2/r$, acts on it towards the Earth's center. As the tangential velocity of the Earth's vortex carries the moon in the orbit, the above central force tends to deviate its path radially towards the Earth, thereby producing *relative motion* with respect to the space medium, and creating an outward centrifugal force in opposition to the above-mentioned inward central force. In this way, a restraining force is produced that regulates movement in the orbit. In addition, gravitational attraction of the Earth is also operative. The stability of such cosmic bodies that do not rotate axially, in their orbits, is more complex than those possessing axial rotation.

9.2 Orbital radii of planets

¹ Period of rotation for Venus being 243 days, its electrical charge, compared to other planets, should be negligible.

In (9.3), it is seen that the velocity-field that produces inward acceleration (and consequently inward radial force) on the Earth, is the resultant field obtained by the superposition of the fields of the Earth's space-vortex as well as the Sun's space-vortex.

Denoting this velocity field (Fig. 9.1 c) by v_0 , (9.2) becomes

$$F = M_e a = M_e v_0^2 / r. \quad (9.4)$$

Equating the electrical repulsive force between the Sun and the Earth, with the above attractive force between the Earth and the Sun

$$(c / 4\pi) Q_s Q_e / r^2 = M_e v_0^2 / r, \quad (9.5)$$

Since the solar electric charge Q_s is a constant, from above

$$r \propto Q_e / M_e v_0^2, \quad (9.6)$$

It follows from (9.6) that *the orbital radius of a planet (with axial rotation) is directly proportional to its electric charge, and inversely proportional to the mass. It also varies inversely as the square of the resultant velocity field, which, as defined above, is greater than the orbital speed of the planet.*

The constant of proportionality in (9.6) can be found by substituting the values (see Appendix, A3) of the solar charge, orbital radius, mass and the resultant velocity field (v_0) of any of the planets. We can, however, choose Jupiter, which being the largest planet, and located in an orbit about six times lesser distant than Neptune, has better possibility of accuracy of its astronomically measured properties, like diameter, distance, rotation etc.

$$\text{From (9.6),} \quad r_j = K Q_j / M_j v_0^2, \quad (9.7)$$

where, r_j is the radius of Jupiter's orbit, Q_j is the electric charge of Jupiter; M_j is the mass, and v_0 is the resultant velocity field on Jupiter (see Appendix, A3).

$$\text{From (9.7)} \quad K = (r / Q_j) M_j v_0^2.$$

Substituting the values in the above equation

$$K = (778 \times 10^{11} \text{ cm})(8.34 \times 10^{29} \text{ g})[(41.8 + 13.1) \times 10^5 \text{ cm/s}]^2 / 6.4 \times 10^{26} \text{ esu},$$

$$\text{from which} \quad K = 3.06 \times 10^{30} \text{ g cm}^3 / \text{esu. s}^2. \quad (9.8)$$

The orbital radius of the Earth is now found by substituting in (9.7) the values pertaining to Earth (see Appendix, A3), as follows.¹

$$r_{\text{earth}} = (3.06 \times 10^{30} \text{ g cm}^3 / \text{CGSEs}^2)(1.85 \times 10^{23} \text{ CGSE}) / (2.25 \times 10^{27} \text{ g})(37.6 \times 10^5 \text{ cm/s})^2$$

$$\text{from which,} \quad r_{\text{earth}} = 176 \times 10^6 \text{ km.}$$

Astronomical measurements¹ show that the Earth's orbit is 150×10^6 km away from the Sun's center.

The orbital radii of some other planets, computed on similar lines, are compared with the accepted values (in bracket) as follows. Mars: 228.8×10^6 km (228×10^6 km); Saturn: 1439×10^6 km (1430×10^6 km); Uranus: 2886×10^6 km (2870×10^6 km); Neptune: 4195×10^6 km (4500×10^6 km). (In case of Uranus, as explained earlier, the velocity field due to axial rotation has not been taken into account, because this planet almost rolls on its side.) The above figures show a striking closeness between the computed values and the experimental measurements.

The constant K determined (9.8) from the properties of Jupiter can be checked from (9.5) using the solar charge Q_s from (7.2), as follows. From (9.5)

$$(c / 4\pi) Q_s = K$$

$$[(3 \times 10^{10} \text{ cm/s}) / (4 \times 3.14)] (0.928 \times 10^{28} \text{ cm}^3 / \text{s}) = 0.2216 \times 10^{38} (\text{cm}^4 / \text{s}) (1 / \text{s}) = K$$

From (4.12), using relationship: $g = 8.6 \times 10^6 \text{ cm}^4 / \text{s}$

$$(0.2216 \times 10^{38} / \text{s}) (g / 8.6 \times 10^6) = 2.58 \times 10^{30} \text{ g} / \text{s} = K. \quad (9.9)$$

In (9.8), using the relationship (4.5): $\text{cm}^3 / \text{s} = \text{esu}$

$$K = 3.06 \times 10^{30} \text{ g cm}^3 / (\text{cm}^3 / \text{s}) \text{ s}^2 = 3.06 \times 10^{30} \text{ g} / \text{s}. \quad (9.10)$$

The constant K derived with the solar charge (9.9) is close enough, compared with its value derived with the parameters of Jupiter (9.10).

With derivation of (9.6), and the orbits of the planets calculated from it, the following positive conclusions emerge: *The orbit of a planet is determined by its electric charge, mass, velocity field of the solar vortex propelling the planet, axial rotation of the planet, and the speed of light.* It is also seen that masses of the planets, used for calculation of the orbits (see Appendix, A3), are far different from the accepted values.

¹ PHYSICS (4th Edition), Volume 1, Resnic / Halliday / Krane.

Chapter 10

ON MOTION OF ELECTRON

10.0 Magnetic field –additional facts

In addition to the description of the magnetic field in Section 4.17, the following physical details are discussed.

In Fig.10.1a, an electron is shown moving along the X-axis, uniformly at velocity v relative to space, passing through a transverse plane Y-Z. At each point of the circle of the interface, cut by the plane Y-Z, tangential velocity u of space is $c \sin \theta$; whereas, in Position-1 (Fig.10.1b), when P coincides with the origin, $u = 0$, since the radius of the circle, cut by the interface and the plane Y-Z, is zero there. The maximum value of u is in Position-2 (10.1c) where Y-Z plane coincides with the diametrical plane of the interface, and half of the interface has passed through Y-Z. Thus, when the spherical interface passes through the plane Y-Z up to a horizontal length r_e , a circle enclosing a void opens up in the Y-Z plane with its center coinciding with O, during a time interval r_e / v . Looking from a point on $-X$ axis, the interface of the electron imparts clockwise-spin to the circle of intersection, C, due to which it possesses circulation varying from zero in Position1 to the maximum of $2\pi r_e c$ in Position-2, during time r_e / v . Starting from the instant at Position-2, a reverse process starts, when the circulation imparted by the interface to the successive circles of intersection continuously reduces (10.1d) from the above maximum value to zero in the time interval r_e / v .

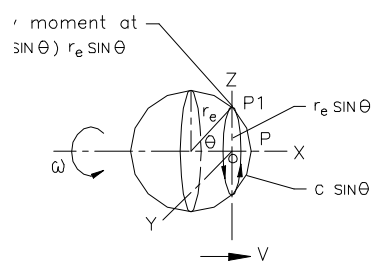

(a)

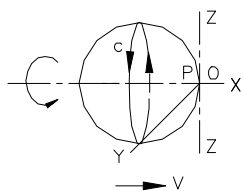

Position-1
(b)

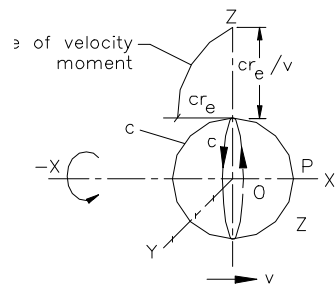

Position-2
(c)

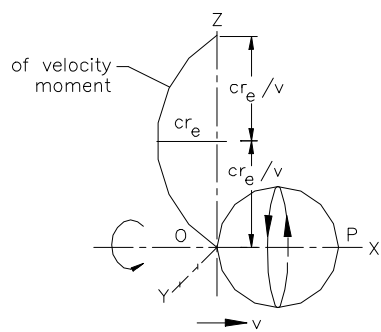

Position-3
(d)

Fig. 10-1

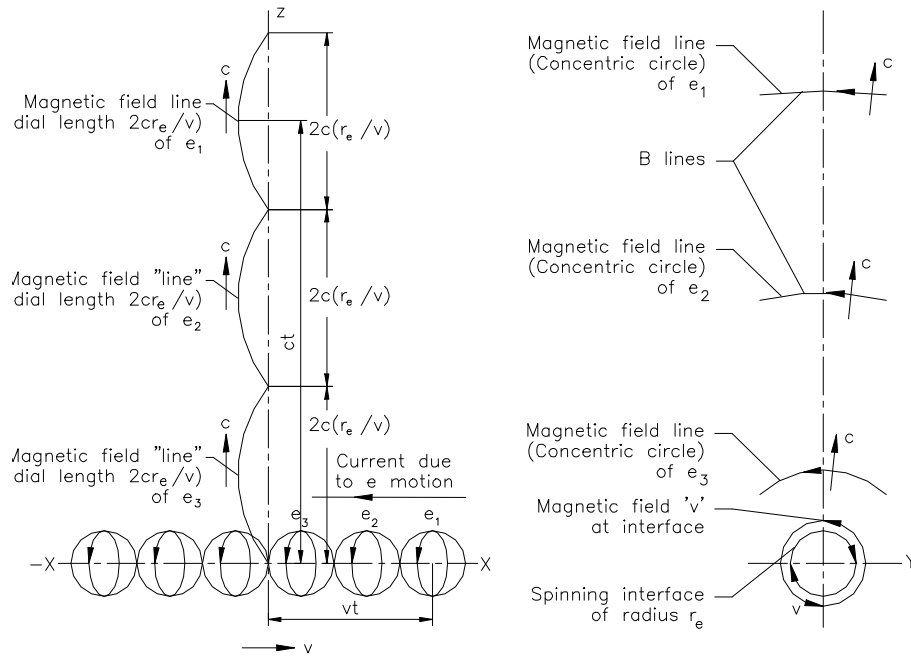

Fig. 10-2

In Fig.10.1a, an electron is shown moving along the X-axis uniformly at velocity v relative to space, passing through a transverse plane Y-Z. At each point of the circle of the interface, cut by the plane Y-Z, tangential velocity u of space is $c \sin \theta$; whereas, in Position-1 (Fig.10.1b), when P coincides with the origin, $u = 0$, since the radius of the circle cut by the interface and the plane Y-Z is zero there. Maximum value of u is in Position-2 (10.1c), where Y-Z plane coincides with the diametrical plane of the interface, and half of the interface has passed through Y-Z. Thus, when the spherical interface passes through the plane Y-Z up to a horizontal length r_e , a circle enclosing a void opens up in the Y-Z plane with its center coinciding with O, during a time interval r_e / v . Looking from a point on $-X$ axis, the interface of the electron imparts clockwise-spin to the circle of intersection, C, due to which it possesses circulation varying from zero in Position1 to the maximum of $2\pi r_e c$ in Position-2 and during the period r_e / v . Starting from the instant of position-2, a reverse process starts, when the circulation imparted by the interface to the successive circles of intersection continuously reduces from the above maximum value to zero in the time interval r_e / v , (10.1d).

Referring to Fig.10.1a, a point P_1 , at the intersected circle, has the tangential velocity, $c \sin \theta$, and the radius of rotation, $r_e \sin \theta$. The velocity moment, $(c \sin \theta) r_e \sin \theta$, varies from zero in Position1, to the maximum, $(c \sin \pi / 2) r_e \sin \pi / 2$, that is, $c r_e$, in Position -2 and during the time interval r_e / v . With this uniform motion of the electron, the tendency of its spinning interface to impart circulation to the circle intersected by the Y-Z plane is reacted by the fluid-space as

a “counter spin impulse”, which manifests as a concentric circle with magnetic field at each point of the circle –the effect transmitting out radially at speed c (Fig.10.2).

During the time interval, $2r_e / v$, which is the time required for the interface to pass through the Y-Z plane, the “radial spread” of the “counter spin impulse” in the Y-Z plane will be, $c (2r_e/v)$, since the field and potential effects are transmitted in space at constant speed c . This “radial spread” is to be taken as the “radial width” of each circular magnetic field line (Fig.10.2). Along half of the radial width, which is, $c r_e / v$, the “velocity moment” varies from zero to $c r_e$, and then decreases back to zero. The maximum gradient of the velocity moment within half of the radial-width of the magnetic field line is: $c r_e / (c r_e / v)$, that is, v ; which is defined as the magnetic field vector B , acting at each point of the interface-circle intersected by the Y-Z plane. If the electron moves at speed approaching c , then, a circle of radius r_e , coinciding with the interface in the plane Y-Z, will have at each of its point tangential magnetic field B , now approaching c in its magnitude. Since the circulation, $2\pi r_e c$, creating the B vector around a circle with perimeter $2\pi r_e$, initially, is distributed on the successive circles with increasing radii, the magnetic field B at a radial distance r from the origin and in the Y-Z plane, for the electron moving at velocity v relative to space, will be

$$B = v r_e / r. \quad (10.1)$$

The “counter spin impulse”, as the reaction from space, causes the direction of the B -vector opposite to the interface-spin (Fig.10.2). As seen from (10.1), *an electron, with zero velocity relative to space, will have no magnetic effect.*

10.1 Ampere’s Law

From Ampere’s Law, the lines of magnetic induction for a straight wire carrying a current i , are concentric circles centered on the wire. At a radial distance r , B is given by

$$B = \mu_0 i / 2 \pi r, \quad (10.2)$$

where μ_0 , the permeability constant. Amperes’s law is derived below with the use of charge-equation (4.4) as follows.

The electric current i due to a single electron is:

$$i = dq / dt = q_e / dt. \quad (10.3)$$

An electron in linear motion at velocity v crosses a transverse plane (discussed in Section 10.0) in a time duration, $2r_e / v$. Substituting this quantity in place of dt in (10.3), and expressing q_e in terms of r_e and c from (4.4)

$$i = (\pi/4) (4\pi r_e^2) c / (2r_e/v) = \pi^2 r_e c v / 2. \quad (10.4)$$

Rearranging terms in (10.4)

$$v = i (1 / \pi r_e) (2 / \pi c) (2 / 2) = i (4 / \pi c) (1 / 2 \pi r_e). \quad (10.5)$$

From (10.1), when $r = r_e$, $B = v$. Substituting in (10.5), B in place of v , and r in place of r_e ,

$$B = i (4 / \pi c) / 2 \pi r. \quad (10.6)$$

From (4.5), $\mu_0 = 2 / \pi c$. Substituting, in the above equation

$$B = 2 i (\mu_0 / 2 \pi r), \quad (10.7)$$

which is Ampere's Law, except for the coefficient 2, which could appear due to an axisymmetric charge distribution in the electron vortex, rather than the assumed spherical symmetry of a point-charge.

10.2 Momentum, kinetic energy, and inertia

Consider motion of the *spherical interface* of the electron relative to space medium, neglecting for the present, the space circulation of the vortex around it (Fig.10.3a). The space-less void within the interface, during motion, leaves a cavity trailing behind it (Fig.10.3b). The displaced space, ahead of the moving-interface, circulates back to fill the cavity, similar to what can be expected in

Fig. 10.3 a

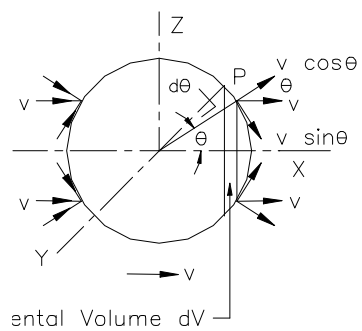

Fig. 10.3 b

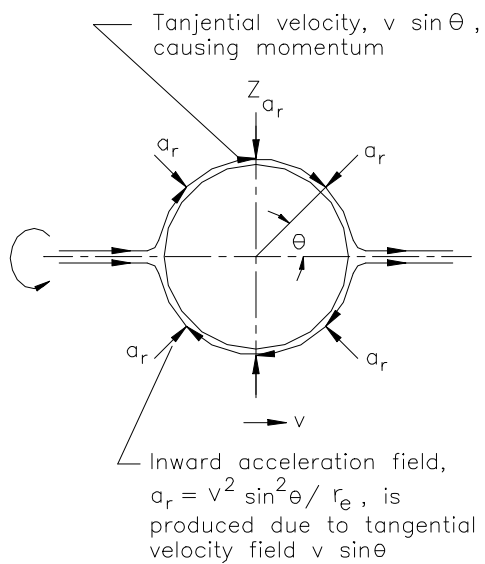
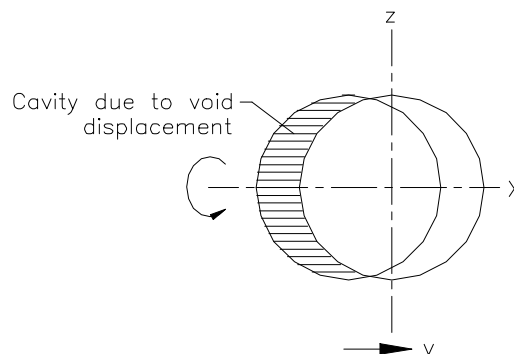

Fig.10. 3 d

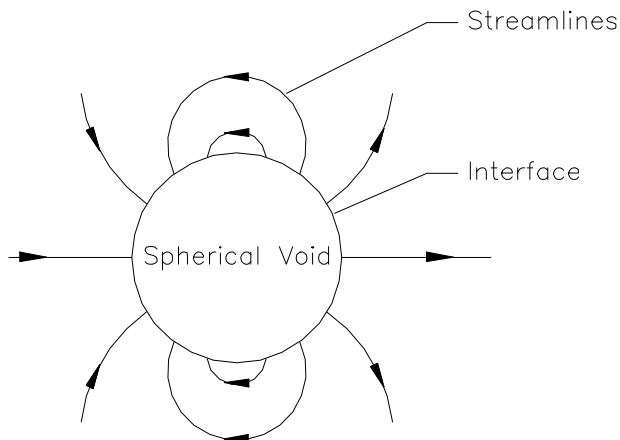

Fig. 10.3 c

the process of the uniform motion of a spherical body in an ideal fluid (Fig.10.3c). The circuitous motion of the fluid-space around the interface creates an inward acceleration field on the front half of the interface as a reaction from space. The work done in overcoming this reaction creates velocity fields that carry the interface continuously forward due to zero viscosity of space. A possible analysis is as follows.

The interface is moving relative to space (Fig.10.3a) at uniform speed v displacing the fluid space. As shown in the figure, a point at the interface displaces space horizontally at velocity v , which has two components, radial and tangential, as shown. While the radial velocity components at the front of the interface indicate the outflow velocity of space, similar velocity components at the rear are due to the inflow of the fluid space into the cavity left behind due to the interface motion (10.3b). Therefore, as regards to contribution to the work done in moving the interface, the rear radial velocity field cancels the work done by the front radial fields. The tangential velocity component $v \sin\theta$ at each interface point, however, remains as the resultant velocity field.

In Fig.10.3a, an infinitesimal element of the interface of void-volume, $dV = (\pi r_e^2 \sin^2\theta) r_e d\theta$, displaces space at velocity $v \sin\theta$ as shown above. From mass-equation (4.6), the mass of this element $dm = dV c = (\pi r_e^3 \sin^2 \theta d\theta) c$. The momentum of this element is defined as

$$dp = dm (v \sin \theta) = c v \pi r_e^3 \sin^3 \theta d\theta.$$

Integrating over the whole interface for the momentum, varying θ from 0 to π

$$p = \int c v \pi r_e^3 \sin^3 \theta d\theta = [4\pi / 3. r_e^3 c] v.$$

From mass equation (4.6), substituting the quantity in the bracket by m_e

$$P = m_e v. \quad (10.8)$$

This expression for momentum comes out to be the same as in classical mechanics. It, however, gets clear that *if the electron does not have the central void it will neither have mass nor momentum.*

The tangential velocity $v \sin\theta$ produces at each point on the interface (Fig.10.3a), an inward radial acceleration, $a_r = v^2 \sin^2 \theta / r_e$, against which, at the front-half of the interface, the space is displaced. Considerations will show that a linear displacement of the interface up to a length, r_e , sets the volume of space equal to its void-volume in motion at velocity v , whereas, only *half of this volume* flows out against a_r . As calculated above, consider an element of volume dV , with mass, $dm = (\pi r_e^3 \sin^2 \theta d\theta) c$. The work done in displacing space of the volume dV , of equivalent mass dm , against the acceleration field a_r , and up to a length r_e (linear motion of the interface) is defined as kinetic energy

$$dE = dm a_r r_e.$$

Integrated over half the surface of the interface, varying θ from 0 to $\pi / 2$

$$E = [\int c (\pi r_e^3 \sin^2 \theta d\theta) (v^2 \sin^2 \theta / r_e) r_e] = (9\pi/64)[4\pi/3 \cdot r_e^3 c] v^2.$$

Replacing the quantity in the bracket by m_e from mass-equation (4.6)

$$E = (9\pi/64) m_e v^2 \approx (1/2) m_e v^2, \quad (10.9)$$

which is close to the expression for the kinetic energy in classical mechanics. The kinetic energy is due to: (a) motion of a body *relative to space*; and (b) production and *association of the velocity field* with a moving body.

Kinetic energy of a moving body is the *most basic state* of energy, which is *independent* of the structural energy of the body. The velocity field can have any value varying from zero to the speed of light, whereas, in material structure, the maximum circulation of space must necessarily reach c and remain constant.

The Principle of inertia points towards the property of non-viscosity of space, as well as void-content in matter. The acceleration field in the structure of the electron, and also the gravity field are *inward* fields that keep the electron held in position with “pressure”¹ from space. A body displaced from rest acquires velocity field and momentum. On collision with other bodies, the momentum is transferred as per the existing principles of classical mechanics. Further, an electron in motion cannot acquire velocity field if it is a *point mass*, because a *dimension less* point can have no energy; energy requires certain zone, howsoever small, for its distribution. A point-mass can possess neither momentum nor

¹ The word “pressure” is used in material media like hydrostatic pressure on the surface of a body. The force-effect of the inward fields on the electron interface will need coining of another suitable expression.

kinetic energy. It is the *spherical interface* of the electron at the vortex center that, combined with the non-viscous space, exhibits the mechanical as well as the electrical properties including inertia. With this description of inertia it gets evident that Descartes, the discoverer of the principle of inertia in the form it appears in Newton's equation, had rightly postulated *property less* space, and assigned matter with property of *extension*.

As stated earlier, the other aspect of inertia as per which a body at rest continues to remain so, follows from: (a) the *inward* acceleration field (F.g.10.3d) which acts radial on each point of the interface of the electron; and (b) the radial gravitational field acting *inward* on each point of the interface. The above two fields hold electron stationary if the same is un-interacted by other external forces; In case of neutral atoms where charges are nullified, the inward gravity field tends to hold them stationary in space. Thus, a force applied externally on an atom, is reacted by the structural forces of the atom, till the applied force moves it, creating velocity field, which carries the atom perpetually, if not opposed by other forces. The principle of inertia remains un-explained in contemporary physics, because, the *void-space* concept, adopted presently, enables neither development of a physical theory on structure of matter, nor helps in pinpointing the cause of reaction from space on a moving matter. The point-mass concept of electron is the additional handicap in explaining inertia.

10.4 Centrifugal force

The above analysis of inertia is applicable to the linear motion of electron (matter) relative to the medium of space, which is stationary with respect to the surface of the Earth. In case of a uniform circular motion in relatively static space, the velocity field associated with the body describing the circle undergoes changes in direction, producing acceleration (outward); thus creating centrifugal force directly proportional to the square of the speed, and inversely proportional to the radius, as per Huygens rule (1673). If an electron (or, atom) is located within a circular space vortex, and rotated around the vortex center with no relative motion with respect to its surrounding space, there will not be generation of any additional velocity field and, hence, no centrifugal force will act on it. *Production of centrifugal force in a body describing a curve requires relative motion with respect to its neighboring space.*

10.5 Constancy of the electron mass

As discussed earlier, an electron in motion relative to space is associated with velocity field that endows electron with momentum and kinetic energy. As long as the speed of electron does not reach c , the fluid-space ahead of the electron

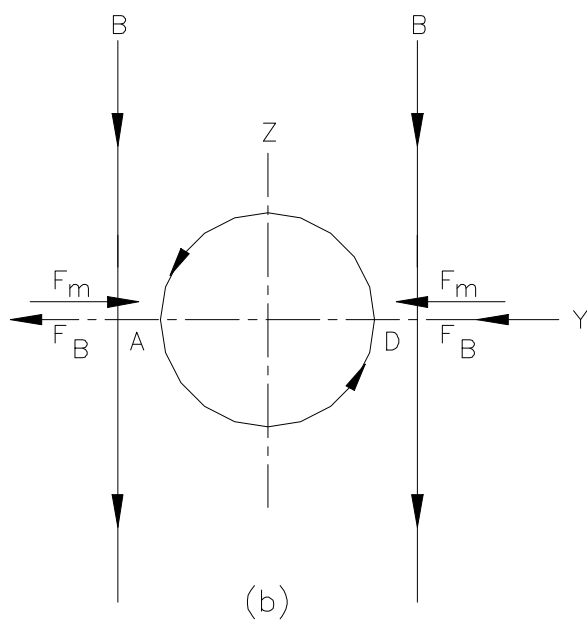
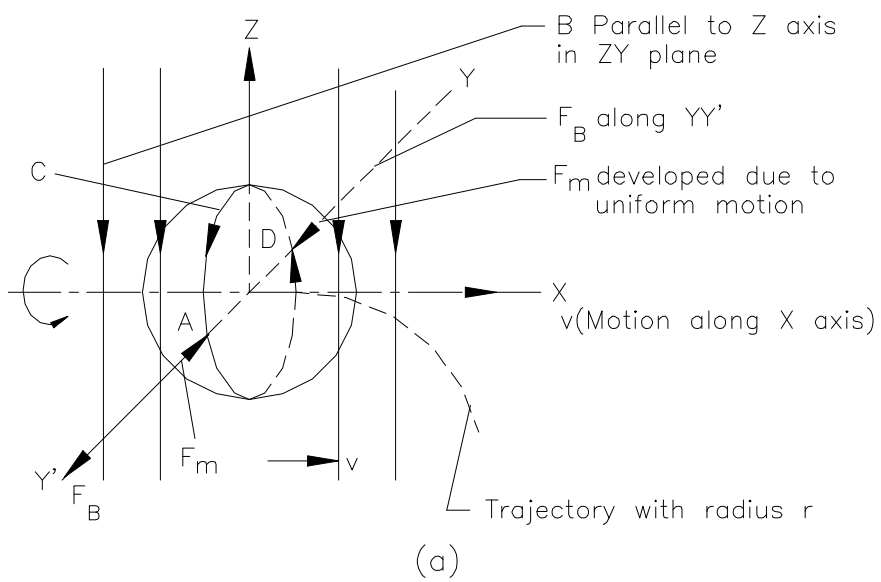

Fig. 10.4

gets displaced at the same speed as the moving interface of the electron. However, when the speed of electron approaches c , the flow of space ahead of the electron reaches the limiting-speed, and breaks down into sub-micro voids that may form stable electrons / positrons. If a beam of charged particles, say, electrons or protons, accelerated at speed close to c , collides with an oppositely moving beam of the same particles, the collision will create out of the kinetic energy of the particles in the beam, several additional particles (stable as well as unstable), starting *invariably* with electrons and positrons. In such experiments of particle collisions, the additional particles formed are created from the velocity field (space-circulations produced on impact between particles) associated *externally* with the colliding particles, and are not necessarily the particles expelled from their internal structure. *The mass of the particles moving either with the space, or relative to space, does not change with speed.* What may happen, however, is the *reaction from space* on all moving matter, which becomes noticeable at speeds close to c when particles are accelerated in particle accelerators.

An electron is shown moving uniformly (Fig. 10.3a) at velocity v relative to space at right angles to the plane Y-Z. At point P, due to tangential velocity, $v \sin\theta$, an inward acceleration: $a_r = v^2 \sin^2\theta / r_e$ is produced. The maximum value of a_r is, v^2/r_e , when $\theta = \pi/2$.

Fig10.4 shows an electron moving relative to space at uniform velocity v along X-axis under a vertical magnetic field B . Consider the interface-circle C, cut by the Y-Z plane, and the points A and D where the Y-Y axis meets this circle. The inward acceleration, a_r , acts radial on each point of C, and creates a force:

$$F_m = m_e v^2 / r_e = m_e (v^2 / c^2) (c^2 / r_e), \quad (10.10)$$

acting inwards on the points A and D. In addition to these mechanical forces arisen due to the electron motion relative to space, there is also a magnetic force:

$$F_B = q_e v B, \quad (10.11)$$

which is produced due to the external B acting on the magnetic field, created by the moving electron. Looking from the +X-axis towards the approaching electron, this field will have clockwise direction, opposite to the anticlockwise direction of the interface-spin (Fig.10.4b). The magnetic force on the electron will be in the direction shown, due to which its trajectory in the X-Y plane will be as shown in Fig. 10.4a. Expressing q_e in (10.11) in terms of r_e and c , from (4.4),

$$\begin{aligned} F_B &= (\pi/4) (4\pi r_e^2 c) v B = (\pi/4) (3/r_e) [(4\pi/3) r_e^3 c] v B. \\ &= (\pi/4) (3/r_e) m_e v B \end{aligned} \quad (10.12)$$

where the quantity within the bracket, from mass equation (4.6), is m_e .

The net force on the electron is, $F_B - F_M$, at point A, causing the electron to move in a trajectory of radius r . The centrifugal force on the electron to oppose the above deflecting force is

$$m_e v^2 / r = F_B - F_M. \quad (10.13)$$

It is seen from (10.10) that F_M is directly proportional to v^2 / c^2 , whereas, from (10.11), F_B is directly proportional to v . Therefore, at $v \ll c$, there is hardly any reduction in the net force due to F_M , however, at speeds nearer to c , the increased value of F_M will reduce the net force appreciably (10.13), thereby, making the trajectory of the electron flatter, as observed experimentally. Substituting F_B from (10.12), and F_M from (10.10) in (10.13)

$$m_e v^2 / r = (\pi/4) (3/r_e) m_e v B - m_e v^2 / r_e$$

from which,
$$r = 4 v r_e / (3 \pi B - 4 v) \quad (10.14)$$

whereas, classically,
$$r = m_e v / q_e B. \quad (10.15)$$

Expressing m_e and q_e in (10.15) in terms of r_e and c from (4.6) and (4.4)

$$r = [(4\pi/3) r_e^3 c] v / (\pi/4) (4\pi r_e^2 c) B = 4v r_e / 3\pi B. \quad (10.16)$$

A comparison of (10.14) and (10.16) shows that for the same values of v and B , the radius of the trajectory r , calculated from the classical expression (6.14), is smaller than the value computed from (10.16) in which reaction from space is taken into account. Therefore, with increase in v , the value of, r , from (10.14) will increase at a faster rate than from (10.16). If electron is moved at speed c , then from (10.1), B will have maximum value c when $r = r_e$. Substituting c for both B and v in (10.14), $r = 4 r_e / (3 \pi - 4)$; and from (10.16), $r = 4 r_e / 3 \pi$. The ratio of these two values is: $(4r_e / 3\pi - 4) / (4r_e / 3\pi)$, which is: $3\pi / (3\pi - 4) \approx 1.738$. Thus, at speed approaching light speed, the radius of trajectory of an electron moving transverse to a magnetic field of the highest strength, will be 1.738 times larger than the value obtained from classical physics, on account of the reaction from space (generation of additional inward acceleration field on the interface), and not because of increase of its basic mass, as concluded by Relativity theory. *The mass-equation (4.4) is independent of the speed of electron relative to space.*

10.6 Orientation of electrons in electrostatic and magnetic field interactions –the physical aspects

Distribution of velocity-field in the space-vortex of an electron, as discussed earlier, is the maximum in the diametrical plane, at right angles to the axis of rotation. These circular streamlines in the electron vortex, during its motion relative to space, are converted into magnetic field lines (Section-10.0), such that at a

particular instant, points on these streamlines have either steady velocity-field (producing electric field), or *varying magnitudes* of velocity-field, that produce magnetic field. The magnetic field at a point is the *effect* of the *decreasing magnitude* of the velocity-field at that point. Magnetic attraction between electrons in parallel motion, and magnetic repulsion between an electron and a positron in parallel motion, develop maximum at right angles to their motion, because of the above mentioned configuration of the magnetic field with respect to the line of motion of the particles (Figs.10.4, 10.5). Free electrons (considering two of them), assumed *static* and in close range, will reorient their vortices through mutual action of their velocity fields, so that these fields become unidirectional in space in-between them; and thus create an attractive electrical force. Similarly, two electrons in close range, assumed to be in parallel motion, will have such directions of the velocity fields in their vortices so that the magnetic field in-between them, are in opposite directions; and thus create magnetic attractive force (Fig.10.5).

It is a known fact that the direction of an electric current is conventionally taken opposite to the flow of electrons. Applying “corkscrew” rule (Fig.10.6), an anticlockwise direction of the magnetic field around a current carrying conductor, signifies the current direction up the paper. Therefore, the electrons in the current will flow down the paper. And, since the direction of the magnetic field around the current carrying conductor has to be opposite to the velocity field in the electron vortex (Section 4.18), the down-ward moving electrons should have clockwise direction in their vortices. An electron moving away from an observer A will be seen by A to have clockwise vortex as it proceeds forward. There appears to be a *preferred* direction of motion of electron governed by the rotation of space in its vortex, when it moves in its *natural* mode as electric current. That explains the reason for the emission of only *negative* beta particle (electron) from all the beta-active elements existing in nature; because, under the force of expulsion within the nucleus, the particle – either electron or positron (oppositely oriented electron)— released and projected from the nucleus, gets oriented with the clockwise vortex-spin similar to the electron for onward motion.

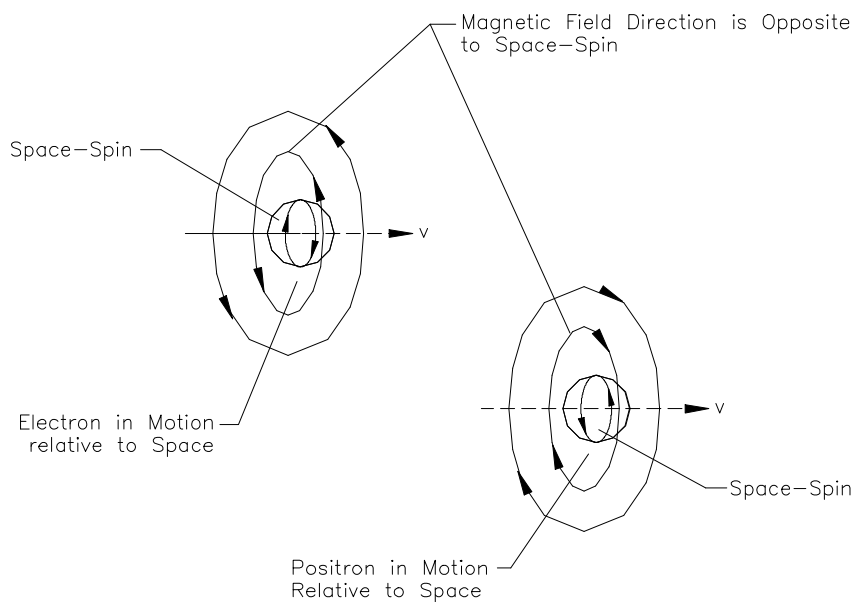

Repulsive Magnetic Force Between Electron & Positron When in Motion

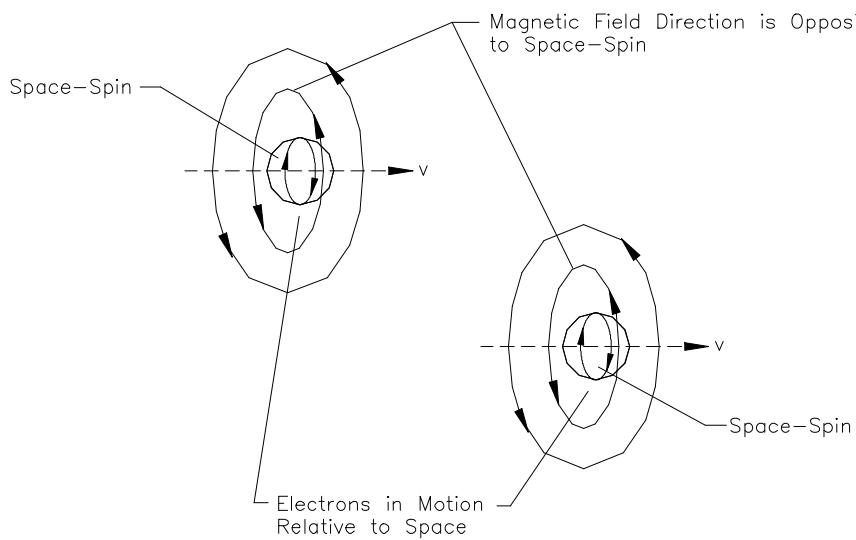

Attractive Magnetic Force Between Moving Electrons

Fig. 10.5

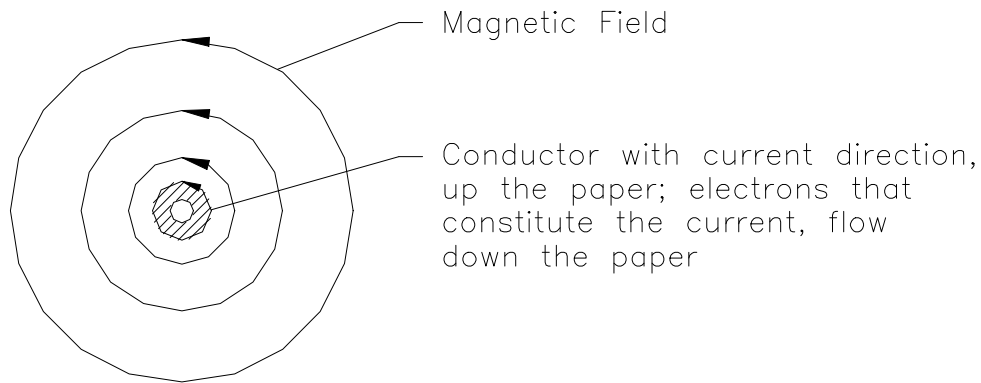

Fig. 10.6

10.7 Annihilation of electron and positron

Under electrical attractive forces (Fig.4.4a), due to unidirectional velocity fields in-between the particles (electron and positron), they rotate as their vortices roll over, moving around each other till their interfaces meet (Fig.10.7). The inward acceleration field c^2/r_e , acting externally on the interfaces, provides the crushing force that brings the particles closer till the vortex fields of each particle are superposed. These fields, being equal and opposite in direction, are nullified and cause annihilation. Fig. 4.4b, shows repulsion between the two electrons due to oppositely directed velocity fields in between the particles, whereas, quantum mechanics wrongly postulates this repulsion due to exchange of virtual photons.

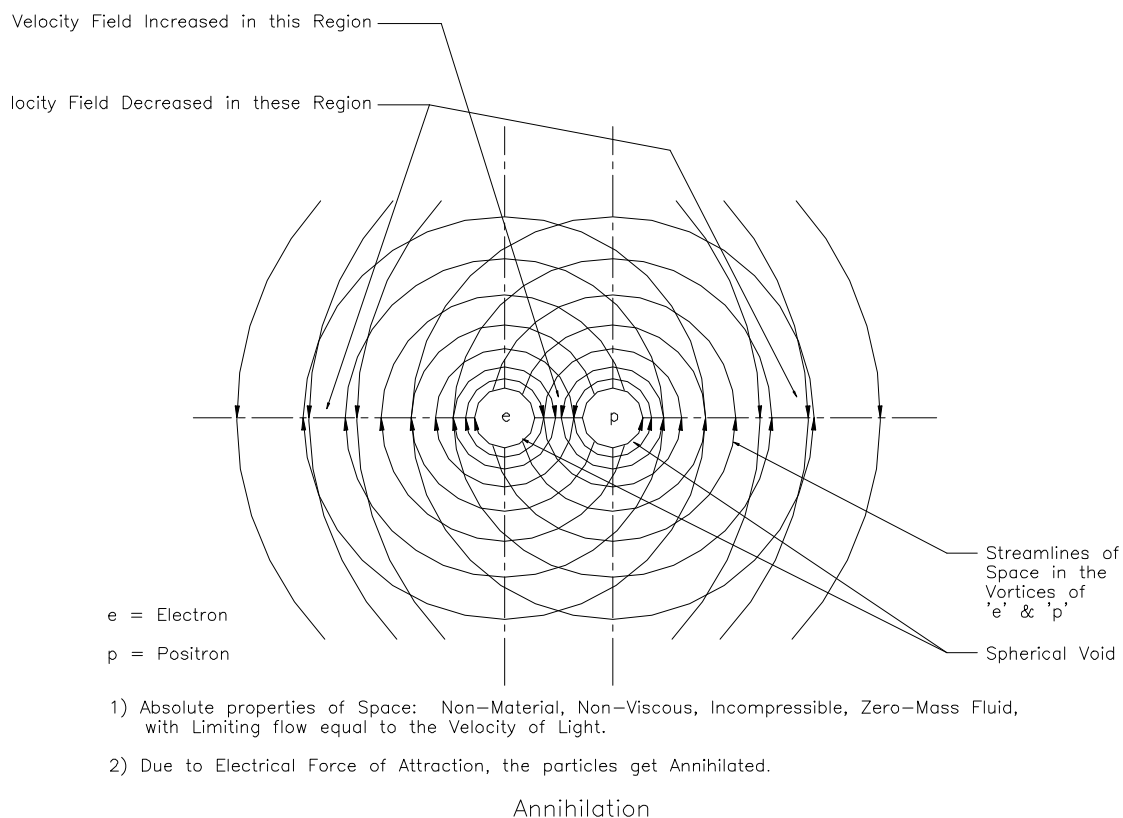

Fig. 10.7

10.8 Orbital electrons

Another example of rotational motion of electrons is in the vortices of atoms. In Fig.(4.11), the simplest atom of Hydrogen is shown. The nucleus, in this case is a neutron enclosed within a space- vortex, which gives it the properties of electric charge, and also another name, proton. The neutron is a dynamic assembly of electrons and positrons because of the natural constraint in the creation of only electron as the stable fundamental particle. The oppositely directed velocity fields of the electron and proton nullify each other in the region external to the atom, thus endowing it with the property of overall neutrality. The nuclear vortex (proton vortex) makes the region in the neighborhood of the nucleus filled with energy – the velocity and acceleration fields—that carry the electron around and impart it with kinetic energy in case of its ejection due to external interaction, if it is of the required strength as it happens in photoelectric effect with larger atoms. The prevailing concepts on the existence of emptiness around the nucleus, makes the continuing orbital motion of the electron an impossible fact. In a larger atom, the nos. of electrons and positrons in the nucleus depend upon its mass, whereas, the nos. of orbital electrons are determined by the electric charge of the nuclear vortex to be neutralized.

The electron vortex, bound with the proton vortex through the common velocity field in between them, rolls over and circles it ceaselessly, there being no loss of energy from either of the vortices due to non-viscosity of space. In quantum mechanics the electromagnetic attraction between the orbital electrons and the positively charged protons in the nucleus is attributed to the exchange of mysterious (virtual) mass less particles, photons, because it is unimaginable as per the tenets of contemporary physics that space-circulation can produce electric charge and a real force on particles.

10.9 Electric current

Electric current in a conductor is the process of motion of the orbital electrons of atoms, in between the atoms, under *attractive* electrical forces between the charged atoms and the neighboring neutral atoms. This explanation is in contrast to the prevalent concept, as per which, the electrons constituting a current are *forced* by the electromotive force applied across the conductor, to move in a circuit against the repulsive forces in between the electrons. Consider three atoms, A, B, C, located adjacent to each other in a conductor of electric current. Let the positive polarity (P) of the generator, created due to shortage of electrons there, come in contact with the atom A. On contact with P, A will lose some of its orbital electrons due to attraction from P, and would thus become positively charged. Consequently, the velocity field in its vortex being no more nullified, will pull out the orbital electrons of B in equal numbers that it has lost to P. Now B, having been positively charged, pulls out the orbital electrons of C and, this way, the process of flow of electrons, from atom to atom, continues in the whole circuit. Though, work is done by the space-vortices of the atoms in pulling the electrons from the neighboring atoms, there is no loss of structural energy from the atoms, that is, no depletion of the strength of the velocity fields in the vortex structure of either the atoms or the electrons due to non viscosity of space. An experimental proof of this lies in the fact that in a super-conducting ring, electric current, once set up, persists indefinitely without any depletion, though it has no external source of energy to maintain the current.

The continuation of current in a normal conductor connected across a dc generator, however, requires continuous presence of voltage at the positive and negative terminals of the generator, for which the generator has to be run by a prime mover. In a dc electrical generator, electromotive force (EMF) is generated by the interaction of a magnetic field with the generator's rotating conductors, when the orbital electrons of the conductor atoms are detached from their orbits and pushed to the negative terminal of the generator. In an ideal dc generator, let us suppose that it has zero input towards the no-load losses (friction, windage) Then, the only power required to be given to the generator is dc excitation to produce the magnetic field. On no-load, though EMF is induced with rotation, the excitation of the generator does not produce reaction on the prime mover, and the excitation power can be kept constant on no-load as well as on load. It remains as heat-energy while maintaining the magnetic field in the excitation sys-

tem. Thus, unlike the prime mover of the generator, which requires additional power from no-load to the loaded condition, the exciter does not draw additional input on load. To conclude, production of EMF does not require any energy in an ideal friction less generator, since the excitation power is not consumed and is available in the exciter coils as heat. Now, the question arises—and this is the crux of the issue—that if the generation of EMF did not consume any power in the ideal generator, how can work be done by the EMF (which did not take any energy for its production) in pushing electrons against their repulsive forces to maintain the load current, since, as stated before, it is conventionally believed that the energy of EMF is responsible to maintain the current in electric circuits? We thus see that the current in the circuit is maintained, as said before, by the attractive electric force between the positively charged atoms and the released orbital electrons available at the negative terminal of the generator.

The reaction against the prime mover on account of power generation occurs when the generator is loaded, because, the EMF induced in the conductors of the generator has, as per Lenz's law, such polarities that the direction of the armature current (load current) and its associated magnetic field interacting with the exciter's magnetic field, create a torque in opposition to the prime mover. This torque can be reduced by suitably designing the configuration of the generator conductors and the exciter's magnetic field such that, while the direction of the armature current is still as per the Lenz's law, the armature reaction is considerably reduced. With this system, energy conservation law can be violated by producing more output power than the input.

Chapter 11

ON LIGHT – ADDITIONAL FACTS

11.0 Wavelength and frequency

The frequency of light in thermal radiation (Fig. 5.3) is determined by the nos. of atomic oscillations in unit time, assuming that the oscillations are continuous. The shells of light produced in annihilation, as well as atomic vibration, have their centers fixed with the source (assumed stationary relative to space) while the wave front, with a fixed radial distance within each shell (wavelength), transmits at speed c relative to space. Each shell of light at certain position is a new shell, created at that position from the latent potentials there. In modern concept of light, a photon is postulated as a “packet of energy”. In fact the packet of energy, clearly spelt out, is the “energy released in unit time”. The photon is understood to have its center moving in void space at constant speed of light relative to the source. A light-shell is transmitted in space at a constant speed c because of the very nature of fluid-space. But, there is no reason why a photon too moves in void-ness at constant speed c . As to how the concept of frequency is related to a photon is least understood, except that, it, perhaps, vibrates transverse to its motion. And if it wobbles transverse to its line of motion a number of times say, f , in unit time, while traversing in space at speed c relative to the source, then, f will have meaning for a photon only after it has traveled for a unit time. Again, what characteristics of a photon can be assigned to describe its wavelength? These obscurities on the physical aspects of a photon are enough to reject photon-theory of light. Though, it is well known that the classical concepts of wavelength and frequency are inapplicable for a photon in quantum physics, in the absence of a physical picture, there appears to be serious conceptual errors, leading to mathematical discrepancies in the very basic relationship between energy and frequency in the Planck energy equation, analyzed below.

11.1 Planck Energy Equation

Based on the concepts of Maxwell-Hertz, that electromagnetic (light) energy is *given off* from electrical oscillators Planck believed that the orbiting electrons inside the atoms of a glowing solid-emitter radiated electromagnetic waves in different quantities, the frequency being determined by the vibration of the oscillator. The classical picture was revised based on his observed experimental fact when he assumed that an oscillator, *at any instant*, could have its total energy (potential, kinetic) only as an integral multiple of the energy quantity hf , where h is a universal constant (experimentally determined) and f is the frequency of vi-

bration of the oscillator. Thus, the light energy can be absorbed or emitted in an *indivisible* quantum of magnitude hf . Planck energy equation is:

$$E = h f. \quad (11.1)$$

It can be also written as

$$E / f = h. \quad (11.2)$$

It is seen from (11.2) that “ h ” is the energy associated with one oscillation of the vibrator on the following basis. It has been shown (5.18) that one shell of light produced due to atomic vibration does have energy close to the experimentally determined value of h . Though Planck believed that the oscillator emits its own energy (kinetic, potential) that it possesses structurally, by deriving h from the gravitational potential in space external to the oscillating atom, a new fact has been brought to light: that the “least energy” produced (in each shell of light) is “ E / f ”. Therefore, the quantity “ $h f$ ” is, actually, the energy contained in f numbers of *successive* light-shells produced by the oscillator in unit time, and can no more be an “indivisible quantum” available at *an instant*, which Planck’s concluded.

Further, as stated earlier, the structures of the oscillators, either electrons or atoms, are not suited to *absorb* or *emit* energy—a serious misconception continuing since Maxwell’s theoretical conclusion that oscillations of electric current leads to *loss* of energy from the system in the form of electromagnetic waves. The concept that heat and light energy get *detached* from the oscillating atoms is corroborated in the following: “¹...the collisions between atoms and molecules in a gas are said to be perfectly elastic. Although this is an excellent approximation, even such collisions are not *perfectly* elastic; otherwise one could not understand how energy in the form of light or heat radiation could come out of gas.” But such a concept is basically wrong and, as seen later, has led to erroneous postulations at the very basic principles of quantum physics. Even in an oscillating electric current the electrons cannot part with their structural energy (the velocity field in the vortex), barring the phenomenon of annihilation, explained before.

An expression similar to the Planck energy equation was derived (4.15) from the vortex structure of electron. The Planck’s constant for the electron was shown to be different (Sec. 5.2) from the Planck’s constant for the atoms. Its value from the relationship: $h = (4/5) m_e c r_e$ was found to be 7.5 times less than the Planck’s constant. However, for an average atom, Planck’s constant computed was close to the experimental value determined by Planck.

The dimensions of h are of angular momentum—same as the angular momentum of the electron derived before. Though the angular momentum of the electron is 7.5 times smaller than the accepted value of the Planck’s constant, the nearness of the two values may lead to the speculation that the orbital electrons in atoms are indeed the electric oscillators that produce light, as imagined by

¹ The Feynman Lectures on physics, Feynman, Leighton, Sands; Vol. 1, page 10-9

Planck and others, and as is also the prevalent concept. With this conjecture, however, following difficulty arises. An atom shows overall electrical neutrality in the region beyond the orbital electrons, where only the gravitational field of the atom should exist. On account of this, h has been computed theoretically with the considerations of a time-varying potential due to gravitation alone. This is not to say that a charged atom will not produce light; rather the value of h obtained from an assembly of charged oscillating atoms should be different, and so also the nature of light (frequency, wavelength) produced therefrom.

Since the structure of light consists of successive shells, it can be said that light energy exists in quanta, where quanta is defined as “energy in each shell”; whereas, the kinetic energy of a moving body, which is proportional to the velocity of the body that can continuously vary, can not have quanta of energy. Any generalization coming out of Planck energy equation, and leading to the concept that all forms of energy occur in quanta, is therefore a misconception.

11.2 Explaining photoelectric effect – the Einstein’s Error

In the vortex structure of the atom (Fig.4.11), the vortices of the orbital electrons, interlocked with the velocity fields of the atomic vortex, are carried round the nucleus as explained earlier. As is well known, the outer orbital electrons, if interacted with light of appropriate wavelength, are released in photoelectric effect. It is now believed in contemporary physics that photo- electrons *absorb* energy from the incident light for their release as well as for the kinetic energy that they possess. On this phenomenon, the following new aspects are to be taken into account.

As stated before, absorption of energy by an electron is, structurally, impossible. The orbital electron, already in circulating motion, possesses kinetic energy due to the velocity field of the atomic vortex. This energy is computed below: The nuclear radius of an average atom (5.15) is, $r_n = 2.39 \times 10^{-9}$ cm. Like an electron, the nucleus too has its axis of rotation and, hence, the maximum electrostatic field is confined in a circular vortex in a plane (more or less), at right angles to the axis of rotation. In the irrotational vortex, space-circulation velocity falls inversely as the radius of rotation. From (4.2), in the electron vortex, $c r_e = \text{constant}$. Applying this relationship also on the nuclear surface,

$$c r_e = u_n r_n \quad (11.3)$$

where u_n is the maximum tangential velocity of space on the nuclear surface in the diametrical plane at right angles to the axis of rotation. Substituting in (11.3) the known values of c , r_e , and $r_n = 2.37 \times 10^{-9}$ cm, we have

$$u_n = (3 \times 10^{10}) 4 \times 10^{-11} / 2.39 \times 10^{-9} = 5 \times 10^8 \text{ cm/s.} \quad (11.4)$$

This velocity, as stated above, falls in the atomic vortex (around the nucleus) inversely as the radius of space rotation. Supposing the radius of rotation

of the outermost orbital electron to be 10^{-8} cm, the space circulation-speed, which is also the tangential-velocity of the orbital electron, will be

$$v = u_n (2.37 \times 10^{-9} \text{ cm}) / 10^{-8} \text{ cm} = (5 \times 10^8 \text{ cm/s}) 2.37 \times 10^{-1} = 1.2 \times 10^8 \text{ cm/s.} \quad (11.5)$$

The kinetic energy of the orbital electron is

$$E_{\text{kin}} = (1/2) m_e v^2 = (1/2) 10^{-27} (1.2 \times 10^8)^2 = 7.2 \times 10^{-12} \text{ erg.} \quad (11.6)$$

Experiments show that the kinetic energy of the photoelectrons is about 8×10^{-12} ergs, which is so very close to the value obtained above (11.6). It is thus seen that Einstein mistook the very *source* of the kinetic energy of the photoelectrons, thinking that it came from the incident light source, whereas, the reality is that the *velocity field in the atomic vortex projects the electron after the incident light has triggered its release*, as explained below.

Production of light due to oscillation of an atom has been discussed before (Sec.5.2, 5.3). Here, the displacement of an atom during its oscillation, and the radial flow of the surrounding space (Fig.5.3) are analyzed. An atomic nucleus, composed of independent electronic voids, closely packed, approximates to a “spherical hole” in space, central with the atom. The atom, during displacement equal to its diameter, leaves a “hole” in its previous location. This “hole” is filled due to radial flow of space at speed c , through the first wavelength, λ , which gets formed as discussed before. The time taken for this flow across the wavelength is λ/c , and the acceleration of space is $c / (\lambda/c)$, which is c^2/λ . Each successive wave-length, formed due to the oscillations of the atom, possesses the above acceleration field across it (radial). Now suppose that the spherical wave front of one of these shells, during its transmission, meets an orbital electron of an atom. The orbital velocity v of this electron is derived from the atomic vortex which subjects it to an inward acceleration v^2 / r , where r is the radius of its rotation. The electron is held by electrical force, created by the above inward acceleration towards the nuclear center. The acceleration field c^2/λ , within the wavelength of the light-shell that meets the orbital electron of the atom, is also inward, that is, towards the light source. For the electron to be released from the atomic vortex, the above two acceleration fields must be equal and opposite. Thus,

$$c^2 / \lambda = v^2 / r \quad (11.7)$$

$$\text{Or} \quad \lambda = c^2 r / v^2. \quad (11.8)$$

Substituting the values: $v = 1.2 \times 10^8$ cm/s obtained above (11.5): $r = 10^{-8}$ cm; $c = 3 \times 10^{10}$ cm, λ comes to, 6.25×10^{-4} cm, which corresponds to the cutoff frequency of, $3 \times 10^{10} / 6.25 \times 10^{-4}$, that is, 0.48×10^{14} cycles/s. For metallic sodium, threshold frequency is about 5×10^{14} sec⁻¹. Considering approximate nature of the assumptions on the orbital radius of the electron, and the radius of an *average size* of nucleus, with which the space-circulation velocity around the nucleus, and

the orbital velocity of the electron were calculated; any better result from (11.8) to conform to the experimentally obtained value of threshold frequency is unlikely. For, the orbital radius of the electron, if supposed to be 10^{-9} cm, rather than 10^{-8} cm, the threshold frequency calculated from (11.8) will be closer to the experimental value.

The additional information given by Eq. (11.8) is as follows. In atomic vortex, the velocity field falls inversely from the nucleus center; and therefore, the inner orbital electrons will have higher speed of rotation. On release by an incident light shell, these electrons will possess higher kinetic energy. It is seen from (11.8) that for a higher value of electron's speed v , the wavelength λ is smaller. It is thus concluded that with higher frequency of the incident light, the photoelectrons released will show higher kinetic energy. This is an experimentally observed fact.

The above analysis shows that the modern concept of photon-nature of light, with *indivisible quanta* of energy possessed by each photon, is a case of the most serious *misconception*, which led Einstein to wrongly treat light-energy, hf , as the *instantaneous* value (when in reality, this energy is produced and accumulated in *unit time*); because this way, the kinetic energy of the photoelectrons, as observed experimentally, could be explained without going deeper into the structure of the atom (that became known later about 1912 through Rutherford's experiments) to determine whether the photoelectrons have any other source, in atomic structure, that imparts kinetic energy to them at the time of their ejection from the atoms.

Though, in Planck's finding, hf is the *integrated* energy of f nos. of shells, he still believed that light energy is distributed uniformly over an expanding set of wave fronts. In contrast, Einstein conceptualized that the energy of light is not distributed evenly over the whole wave front, as the classical picture assumed; rather it is *concentrated* or localized in discrete small regions. With the help of both –the energy integration and localized concentration operations –the right order of magnitude of the kinetic energy of the photoelectrons, as observed experimentally, could be achieved in the quantity hf .

For better understanding of the physical significance of the “indivisible quanta”, we take the following example: Consider the case of a light source producing successive spherical wave pulses or spherical shells of light with frequency f , say 10^{15} /s, and of wavelength 3×10^{-5} cm. In *one second*, the energy produced by f nos. of shells will be hf , that is 6.62×10^{-27} erg s $\times 10^{15}$ /s = 6.62×10^{-12} erg. Now, if it is desired to make the energy “ hf ” *indivisible*, then the independent shells produced successively in one second become indistinguishable, and the new imaginary wavelength of this light will become: $\lambda f = (3 \times 10^{-5})$ cm $\times 10^{15} = 3 \times 10^{10}$ cm; while the frequency will be one, that is, only one wavelength of this large width of 3×10^{10} cm will be produced in one second. The quantum physics will accept the energy of this new shell of light as calculated above, but not the new wavelength and frequency. It will accept the energy content of this new shell of light for explaining the photoelectric effect; and will reject the new wave-

length and the new frequency because the hidden inconsistencies in the photon model will come to the fore.

Without any physical picture, clarity and meaningful explanations, some of these ambiguous conceptions on the fundamental nature of light laid foundation to quantum physics.

11.3 Shortest wavelength of light

As is known, in positronium, the electron and positron circle each other, till their annihilation. At the final instant preceding annihilation, rotation of the particles will reach the limiting speed c , because this is the speed that space has on the interfaces of the particles. In Eq. (11.8), v will be equal to c . Also the distance between the centers of the particles being $2r_e$, the value of r in (11.8) will be $2r_e$. Substituting these values in (11.8), the shortest possible wavelength of light is

$$\lambda_s = c^2 (2r_e) / c^2 = 2 r_e = 2 (4 \times 10^{-11} \text{ cm}) = 8 \times 10^{-11} \text{ cm. (11.9)}$$

The shortest wavelength of light in the universe is produced by the annihilation of an electron and a positron.

11.4 Interaction of X-rays with atoms

High-speed electrons, projected inside a vacuum tube and stopped by its walls, produce X-rays. Here, each electron on impact and almost instantaneous-rebound leaves a “spherical hole” of the size of electron-void at the point of its contact with the wall, to be filled in with the space flowing nearly at speed c . This process is somewhat similar to the light produced during annihilation because, here too, the potentials in space associated with the electron at the instant of impact, die away, producing (which is seen as) X-rays. From each point of the electrons contact with the wall, a spherical shell of light expanding at speed c will arise. Though the energy distribution on the wave front of the shell will fall inversely as the radius of the expanding shell; yet, this shell after transmitting for some distance and with depleted energy density on its wave front, on meeting an atom of a metal, releases an electron possessing kinetic energy almost equal to the kinetic energy of the first electron that produced the X-ray pulse. Indeed, the principle of energy conservation cannot explain this phenomenon because the same is not relevant here. Recognizing that light has the nature of successive shells, and in each shell, across the wavelength, exists an “acceleration field” of constant magnitude independent of the energy density in the wave front; the release of the electron, as discussed earlier in the case of the photoelectric effect, is attributable to this acceleration field, rather than to the energy density in the X-ray’s wave front. If however, the explanation is sought with the idea of energy exchange between the X-ray and the ejected electron, this effect is most puzzling. In the words of Sir William Bragg: ‘It is as if one dropped a plank into the sea from a height of 100 feet, and found that the spreading ripple was able, after traveling

1000 miles and becoming infinitesimal in comparison with the original amount, to act upon a wooden ship in such a way that a plank of that ship flew out of its place to a height of 100 feet.' Yet this effect was not utilized to support the wave nature of light. It was argued that the X-rays when passed through a gas, ionize only few molecules, and had the rays had the wave-property many more molecules should be ionized since the wave will meet all the molecules. This argument does not hold good with the shell nature of light; because, the acceleration field in the X-ray shell has to be in opposition to the acceleration field of the orbital electron, that is, both the opposing acceleration fields must be in line for effective nullification of the electron's bond in the atomic vortex; which requires that the orbital electron, at the instant when it meets the light-shell (wave front), should be moving tangential to it. Obviously, such a disposition of the light shell and the electron can be only in rare encounters and, hence, the numbers of the ionized molecules with one shell of light are expected to be limited. Thus it is seen that wave nature (or more precisely shell nature) of light can explain the ionization of gases by the X-rays satisfactorily.

11.5 Nature of heat

In an atom, the nuclear electrons and positrons, as well as the orbital electrons, create gravitational potential in space, while the electrical potentials are neutralized exterior (beyond the orbital electrons) to the atom, as discussed earlier. Consider a solitary atom A, with its radial gravitational field spread uniformly and symmetrically on the spherical nuclear surface (neglecting the gravitational field of the orbital electrons that, compared to the nucleus, have negligible mass), on account of which it is not a force-free entity. The inward gravitational field will hold the atom stationary, in the absence of any other atom and its gravitational field in the neighborhood of A. Suppose, that for an instant some external disturbance has upset the balance of the fields of A, by partially reducing the *inward* field on its right side, due to which it tends to move to its right from the mean position. This displacement will be opposed by the remaining inward field on the right of A (Inertial effect arisen, as the atom is being moved from rest), forcing the atom to return back to the mean position which may be surpassed due to inertial effect because of the velocity field (space motion) associated with the moving atom. The displacement of A, now to its left, repeats the similar process as described above. The atom has now been set into oscillation not by giving energy to it; but by *reducing* the already existing gravitational field on one side of it. Thus, despite any energy input, the atom continues oscillation indefinitely creating "acceleration field" in its close vicinity, due to the directional changes of the velocity-field accompanying the oscillatory motion of the atom. The "acceleration field" associated with the oscillating atom A is the basic state of energy, presently known as "heat". The medium of space, being non-viscous and mass less, does not retard the oscillation of A by reducing either its frequency or amplitude (in the absence of all other interactions). There is no energy exchange be-

tween a *single* oscillating atom and the surrounding space. The modern view that an oscillating electron radiates off energy and therefore its oscillations slowly die down does not seem to be correct.

The atom A, during the displacement to its right, will create a half spherical shell of light on its left, transmitting out at speed c relative to space (Fig.5.3). Now, suppose there is another atom B in the neighborhood and on the left of A. The shell of light produced by A will meet (not strike as conventionally understood) the atom B. The inward acceleration field in this light-shell produced by A, will upset the balance of the inward gravity fields of B, which will be displaced to its right, sending a light pulse to its left, and a ‘shell’ with *increased* acceleration field to its right; this latter shell (can be termed as “gravitational” shell) will nullify the next light shell that A will send towards B, when A is displaced again to its right having reached the extreme position of oscillation to its left. Also, the atom A, having reached the extreme position of oscillation to its right, and while moving to its left, also creates a “gravitational” shell that transmits towards B and nullifies the light shells produced by B, and transmitting towards A. Through this process, the atom A sets B also in oscillation, and B, through its own light and gravitational shells, that are in phase opposition to the similar shells produced by A, retards the oscillations of A till equilibrium for both the atoms is reached. If A is surrounded by more atoms similar to B, the system will reach equilibrium faster; because there will be more shells at a time (one from each atom) to retard the oscillations of A. Though the atom A, which initially started oscillating without intake of any energy, has not *emitted* (parted with) any of its structural energy, yet through the interactions of its light and gravity shells, the stationary atom B has been set into oscillation creating its own kinetic energy locally; and finally, this system of the two atoms has been brought to the same temperature without absorption of any energy of A by B in its structure. As per the contemporary physics, bodies in a state of equilibrium absorb as much energy as they emit. Whereas, the above analysis shows that a hot body *emits*, neither the kinetic energy associated with its constituent vibrating atoms, nor their structural energy. So also, a cold body does not *absorb* energy in the structures of its constituent atoms, though, when interacted with light shells, its constituent atoms produce oscillating motion, creating kinetic energy in their vicinity due to the imbalance of their own structural forces. However, atoms of colder bodies send radiation pulses to retard atomic vibration of hotter bodies, thus cooling the hotter body, and raising its own temperature.

Whether light from oscillating atoms falling on matter creates a net pressure, is discussed below:

Fig.11.1` shows a free atom A under oscillation, whereas, the atom B is held at the surface of a metal plate S. The lines of action of the inward gravity field F_A of A and F_B of B are also shown. One of the inward gravity field-vectors acting on A has been extended and shown at B (as, F_A). Similarly, the inward field vector of B is extended and shown at A (as, F_B). The atom B is held on the surface due to the inter-atomic forces F of its neighboring atoms in the plate except at the surface S, where F_A interacts with the field F_B of B. The resultant

gravity field $F_B - F_A$ acts at B at the surface S. With the oscillations of A, when it is displaced to the left, a light pulse (shell), described earlier, starts from A, and after a time R/c reaches S, causing a decrease in the strength of F_A there; thereby, increasing the magnitude of $F_B - F_A$, which results in an additional force on B arisen due to its own inward gravity field F_B . During the next displacement of A towards right, through a similar process as described above, the magnitude of F_A increases (as A comes closer to B), which decreases the magnitude of $F_B - F_A$, and thus, leads to a reduction of the force on B. The intermittent pressure pulses on B, (which is held at the surface S by the inter-atomic forces F), set it under oscillations, creating electromagnetic pulses also from B. It is seen that the atom A, without imparting momentum to B through any physical contact, sets it in oscillation through the light pulses produced due to its mechanical oscillations.

In a hollow cavity (black body radiation), the equilibrium distribution of electromagnetic radiation energy, experimentally obtained, shows that at low frequency the energy is proportional to f^2 , while at high frequency there is an exponential drop. The energy-distribution (theoretical) as per the Rayleigh-Jeans law, gives excessive energy for higher frequencies, such that, if integrated over all frequencies, the total energy becomes infinite. Though, classical mechanics places no limit to the frequency of mechanical oscillators (atoms), as per SVT, a limit to the oscillator's frequency is imposed by the speed of motion of the fluid space submerging the atomic vortices (oscillators). The displacement of atoms from their mean positions displaces space, which has a limiting speed of flow as c . If an average radius of atoms is taken as 1.5×10^{-8} cm, the displacement of an atom on either side of its mean position up to a length equal to the radius will involve total displacement relative to space as 3×10^{-8} cm. Time required for the fluid space to move up to this length at its maximum speed is: 3×10^{-8} cm / (3×10^{10} cm/s) = 10^{-18} s. The nos. of light shells produced in one second due to this atomic oscillation will be 10^{18} /s, which is the frequency of the light produced. Thus, the maximum frequency of the oscillators in *thermal* radiation, excluding X-rays and gamma, should be limited to

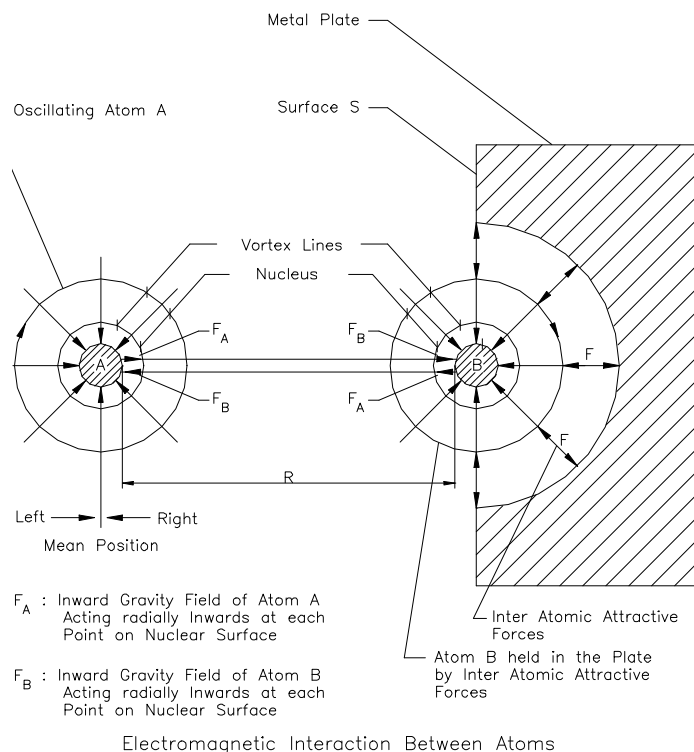

Fig. 11.1

about $10^{18}/s$. It can therefore be inferred that the exponential fall of energy distribution in a cavity at higher frequencies is due to reaction from space at higher oscillation frequencies. The classical concept: that to determine the total energy within a cavity (blackbody radiation), integral has to extend over all the frequencies is based on a misconception that atoms oscillate in a void-space (reaction less) and hence there can be no limit to their frequency of oscillation.

11.6 Bohr's theory on atomic radiation

As per classical electromagnetism, electric charges in acceleration will radiate energy, and hence the orbital electrons in the atom will lose energy, which will cause the emitted radiation energy to change continuously. However, the existence of sharp spectrum lines, are not in accord with the above prediction of the classical theory. As a solution to this problem, Bohr postulated different 'energy states' for an atom, such that when it falls from higher to the lower energy state, it emits a photon with energy proportional to hf as per Plank's energy equation.

It was shown before, in space vortex structure of the atom, the orbital electrons have already their fixed orbits. These electrons, carried by the vortex around the nucleus, can neither lose any energy (structural, potential or kinetic) due to orbital motion, nor change their orbits due to the strong bond created by

the velocity fields in-between the nucleus and the orbital electrons, because “losing energy” (in addition to kinetic energy) by an electron signifies “losing, part of its vortex structure”. Further, the orbital electrons make negligible contribution to the overall gravitational potential of the atom, as seen before, a time-varying gravitational potential produces light. Moreover, the basic error in Bohr’s theory lies in the application of the concept of Plank’s *indivisible* energy quanta hf , in equating the same with the differential energy between the two energy states (composed of the sum of the kinetic energy of the orbital electron and the electrical potential energy of the proton-electron system) Because, just to repeat, the energy hf is the quantity produced in unit time, whereas, the energy released due to the difference between the two energy states of Bohr’s theory is *instantaneous*.

11.7 The Compton effect

Compton’s experiments are said to confirm that the photon is a concentrated bundle of energy. The experiment consisted of a beam of X-rays of known wavelength falling on to a graphite block. He measured the intensity of the scattered X-rays with respect to their wavelength. His conclusion is that the X-rays are not waves but several photons each with energy, “ $h f$ ”. A photon, in his experiment, collides with a “free” electron in the graphite block, like the collision of billiard balls. He treats in his mathematical analysis the “free electron” as the one, which is not bound with the atom of the graphite block, and is at rest. The collision of photon, assumed with a *free* electron, has the following implication.

As is well known, X-rays can damage molecules and ionize gases. And, as in photoelectric effect, will extract electrons bound in atoms. In the latter case, even if the outermost orbital electron is released, its own kinetic energy in the atomic vortex, as shown before, will be about 10^{-11} erg (11.6). By *assuming* collision of the X-ray with a “stationary” electron, the initial kinetic energy of the electron prior to its release from the atom has been *neglected*. In any case, one cannot assume that the X-ray interacts only with a “free and motionless” electron. This kinetic energy of about 10^{-11} erg will be larger for the inner orbital electrons, which rotate at greater speed. For, an electron, in the inner orbit, with an average speed of three times the speed of the outermost electron, will increase the above mentioned kinetic energy to about 10^{-10} erg. The quantity of energy, accounted in Compton’s experiment against the kinetic energy of the recoil electron, is about the same order of magnitude. His concept is that the electron’s recoil energy comes from the energy of the incident X-ray-photon. If an X-ray of frequency 10^{17} is used during the experiment, its energy as per the Plank energy equation will be; $hf = 6.6 \times 10^{-27} \times 10^{17} = 6.62 \times 10^{-10}$ erg, which is not far from the above figure of the kinetic energy of the ejected electron that it would have had in the vortex of the atom due to its rotation prior to the release. On account of neglecting the initial kinetic energy of the released electron and matching this figure with the indivisible energy quanta, Compton’s conclusions on the photon

nature of X-rays become erroneous. The misinterpretation of Compton experiment –that X-rays is not of wave but photon-nature—led to a misleading picture of photon, both qualitatively and quantitatively.

Another misconception in the above experiment is to believe that a bullet-like photon after striking an electron rebounds with a reduced frequency. Evidently, if not talking in a mathematical sense, Compton might have believed that a single photon has, in a physical sense, a frequency; that it oscillates, perhaps, across its line of motion. As stated earlier, frequency for light would be meaningful only if it is defined as the numbers of waves, photons or shells, produced per unit time. (There is, though, an implied meaning of frequency for a single wave or shell of light, in the sense that the inverse of frequency means the time duration for the formation of each wave/shell). But, in the case of a single photon, its wavelength is not known in a physical way except for the mathematical expression c / f , which leads to an imaginary large wavelength of 3×10^{10} cm, and a single frequency, described earlier. Compton's interpretation of his experiment together with the basic concept of the Relativity theory that all kinds of energy should have mass, made photon to possess *hypothetical* mass, momentum and inertia, while the most fundamental issue – as to why a photon's observed uniform motion is at the constant speed of light – remained unknown.

From relevant literature, it is seen that Compton's arguments to assign momentum to a photon run as follows:

As per the classical wave theory of light, if a body fully absorbs the energy E from a parallel beam of light, then a linear momentum E/c is transferred to the body. Based on this he, using Planck Energy equation $E = h f$, derives momentum, p , for an individual photon

$$p = E / c = h f / c = h / \lambda. \quad (11.10)$$

But the “radiation pressure” on a body is otherwise explainable (Sec.11.6) by the interaction of the light shells with the gravity fields of the atoms without absorption of light energy. [Classical physics is equally wrong in the concept of *absorption* and *emission* of light energy]. Further, the use of Planck Energy equation makes a single photon to possess enormous energy, that is, 10^{16} times the actual energy, if we use light of frequency 10^{16} /s, because in reality, the energy of a single shell of light is, 6.62×10^{-27} erg, as determined by Planck Constant.

It is seen that the concept of “energy quanta” misguided Compton too (after Einstein and Bohr) in interpretation of his experimental results.

11.8 Matter waves

Louis de Broglie, guided by certain symmetrical aspects that nature presents, speculated (1924) that, since, light shows dual behavior of a particle and also of a wave, matter too could perhaps have particle and wave-like properties. The discussions on photoelectric and Compton-effect have shown several fundamental

aspects as to why the very concept of photon, carrying indivisible quanta of energy, and its particle-like behavior are misconceptions. Therefore, to associate material particles with wavelike behavior appears, at the very face of it, to be an equally misunderstood idea. However, considering the fluid nature of space and the structure of the electron as a vortex of space, the association of certain wave-aspects with an electron in motion relative to space has a distinct possibility.

An electron, with its central void enclosed within the spherical interface, while in motion, accelerates space in the plane transverse to its motion as explained below. Refer Fig.10.2. During displacement of the interface equal to its radius, its spherical surface displaces space non-uniformly, thus creating radial-outward-acceleration field, which reaches maximum in the Y-Z plane when half of the interface is displaced. This field is symmetrical around the circle formed with the intersection of the interface with the Y-Z plane. If v is the linear velocity of the electron, the acceleration field will spread out to a length of $(r_e / v) c$, since all fields are transmitted in space at c . When half of the interface passes over the Y-Z plane, the acceleration field becomes downward in direction till the interface passes fully through the plane. Thus, in each plane, transverse to electron motion, such acceleration fields are produced and destroyed. Denoting l as the length of the acceleration field

$$l = r_e c / v. \quad (11.11)$$

Multiplying and dividing the right hand side of (11.11) by $(4/5) m_e$

$$l = (4/5) m_e c r_e / (4/5) m_e v$$

which from (4.15) becomes

$$l = (5/4) h / m_e v. \quad (11.12)$$

Eq. (11.12) is similar to de Broglie equation:

$$\lambda = h / m v, \quad (11.13)$$

except for the following major differences: The quantity 'h' in (11.12) is the angular momentum of the electron; and the quantity 'l' is not the wavelength of light that gets produced during the *oscillatory* motion of electron (here linear uniform motion of the electron is under consideration). Even a high-speed linear motion of electron will produce light due to spatial readjustments of the magnitudes of the gravitational potential of the electron at each point, as the electron changes its position relative to space. This effect too is different from the matter wave of de Broglie.

The quantity 'm v' in de Broglie equation (11.13), was understood by him as the 'photon momentum', whereas, 'm_e v' in (11.12) is the momentum of the electron.

Eq. (11.11) is independent of the mass and charge of particles. Therefore, the length l , produced due to the acceleration field on account of the particle's motion, is associated only

with the moving particle –existing in the particle’s immediate neighborhood –and has little to do with propagation of light (whether considered as a photon or a light-shell). The shortest ‘length’ l is associated with the electron motion, and is equal to its radius when its speed approaches light speed, as it follows from (11.11).

Eq.(11.11) is more fundamental equation for de Broglie wave, because from this, Eq.(11.12) has been derived to show the actual physical meaning and limitation of de Broglie equation.

11.9 Diffraction of electrons

When electrons are shot through a small slit, the pattern of their distribution on a screen on which they fall is similar to the one created by a wave, if the wave is made to pass through a slit. In a parallel beam of electrons, space vortex structure of the electrons creates magnetic attraction between them, falling inversely as the distance between the electron’s centers. And at a closer range, electric repulsion between the particles, which falls inversely as the square of the distance, is effective. In addition, the ‘accelerating space’ of de Broglie wave, discussed above, acting in the planes transverse to the motion of each electron, would keep the particles separated. While entering the constricted slit the electrons are *choked* and compressed closer against the above repulsive-forces, while interaction of the electrons with de Broglie waves also takes place. Immediately after their emergence from the slit, the particles are separated due to their mutual repulsion on account of the above forces that are stronger than the magnetic attraction. The ring pattern of electron diffraction obtained on a screen is due to the above repulsive forces that are symmetrical around each electron.

11.10 Constancy of the speed of light in S T R

Einstein postulated that different observers, moving at uniform velocities relative to each other and to a source of light, should find their measurements of the speed of light to be the same, provided they use a defined reflection procedure. Let us suppose that light consists of several *particles* of energy (energy—as conventionally interpreted *today* – such that there is little difference at the quantum level between matter and energy) say, electrons with properties of mass and momentum, being projected from a light source at random in all directions so as to form a uniform spherical distribution. The observers can choose any of these particles for the test. A particular observer, moving in the same direction as his chosen particle, will find its speed different from the measurement of the other observer who is moving against the motion of the particle, as per classical relativity. Similarly, if light is imagined as a swarm of photons, each with mass, momentum and kinetic energy, being emitted from the source at random without any *constant interval* between the two successive photons from the same atom, the Galilean relativity will be applicable, similar to the above cited example of the shower of electrons. In this case also the two observers will measure different velocity for the same photon. But, as shown before, the structure of light is that of successive shells of mass-less energy with a constant time interval between the fronts of the adjoining shells

emitted from *each* atom, as determined by the atom's vibration. It's the time-interval of emission between the successive shells that determines the frequency of light; whereas, in the earlier example of the photon-model of light, the frequency of light is a mere mathematical quantity, E/h , having no relationship with the timings of emission of the two successive photons from the same atom. It is this *haziness* on the physical picture of the frequency and wavelength of a photon that leads to misinterpretations of results of several experiments devised to check the above postulate of STR. The following simple analysis, almost trivial, supports constancy of light-speed (relative to space) measurements by different observers in relative uniform motion.

In Fig.11.3, a source of light S (stationary with respect to space) from which a single spherical shell of light, produced consequent to the annihilation of an electron and a positron located in S is transmitted at a constant speed c relative to the medium of space. When the wave front of this shell meets the eye of an observer O, who is also stationary relative to space, let him record this instant assuming that his time is the same as that of any other observer (universal time) who may even be in motion relative to space. Let him also record the instant when the tail-end of the shell passes away from him. If λ is the radial width of this light-shell (wave length of this shell of light is r_e , equal to the electron radius), then, from the ratio of λ and the time difference between the above two instants, say t_1 , the observer can calculate the speed of light from the relation

$$\text{Speed} = \text{wavelength} \times \text{frequency}$$

$$\text{Or} \quad c = \lambda (1/t_1) = \lambda / t_1 \quad (11.14)$$

because light-effect is transmitted *within* the wavelength at speed c relative to the stationary space. Let S produce similar shells in succession such that the tail end of a shell coincides with the front of the following shell. If the nos. of shells received by O in unit time is f , he will calculate the distance covered by the f nos. of shells in unit time as $f\lambda$, and time duration as ft_1 . With the ratio of these two quantities he will get the value of c , same as before. It is seen that the measurement of the light velocity across one wavelength is the same as across any of the successive wavelengths, provided the successive shells are *similar* with *no interruptions* in between. Now let O move with a uniform velocity v relative to the static space towards S, and record his timings across only one shell. Because his velocity relative to the light shell now is $v + c$, time elapsed across one shell will be

$$t_2 = \lambda / (c + v) \quad (11.15)$$

which is shorter than t_1 measured earlier. The moving observer's eye interacts with the light within the shell for a shorter duration now and, hence, he sees the wavelength as:

$$\lambda_m = \text{length through which the light effect is transmitted in time } t_2$$

$$= c t_2 = c \lambda / (c + v). \quad (11.16)$$

The nos. of shells meeting the eye of the observer in unit time from (11.15) will be

$$f_m = 1 / t_2 = 1 / [\lambda / (c + v)] = (c + v) / \lambda. \quad (11.17)$$

The moving observer can now determine the light speed from (11.16) and (11.17) as:

$$\text{Speed of light} = \lambda_m f_m = [c \lambda / (c + v)] (c + v) / \lambda = c. \quad (11.18)$$

From (11.14) and (11.18) it is seen that the observer, in moving as well as stationary states, finds that the speed of light is constant; and he reaches this conclusion without sacrificing the traditional concept of time.

In the well-known experiment of Sagnac, a beam of light is split into two halves that travel around closed identical paths (reflected through mirrors) in opposite directions, and combined again in a detector to examine their interference pattern. The rotation of the apparatus produces shift in interference fringes as a function of the angular velocity. From (11.16) and (11.17) the reflecting mirrors along one path, rotating opposite to the light beam, will ‘see’ shorter wavelength and, proportionately, more of light-shells in unit time (frequency); while the mirrors rotating in the same direction as the light beam in the other path, will see longer wavelength and lesser nos. of the light-shells in the same time interval. On account of this, the wavelength as well as the frequency of the two beams reaching the detector will be different and, consequently, a shift in the interference fringes will occur. The product of the wavelength and the corresponding frequency for each path of the beam remaining the same, the mirrors placed in the two paths (observers) will find the same value of the velocity of light. Therefore, on rotation of the apparatus, appearance of the shift in the interference fringes in Sagnac’s experiment should not be taken to mean that the light has different speeds (relative to space) along the two paths.

Above interpretation of Sagnac experiment can be confirmed by increasing the nos. of reflecting mirrors in each path; in which case the shift in the interference pattern should increase.

The effect of light at a space point involves creation of light shell there from the already existing gravitational potential at that point, and its further transmission. This process repeats continuously as the light shell traverses each point in space. In the various experiments, set up to determine the light speed, only transmission aspect of light is taken into account, neglecting the process of the formation of the wavelength—the radial spread of light. That is why a “ray” of light, continuously produced from a source, is supposed in

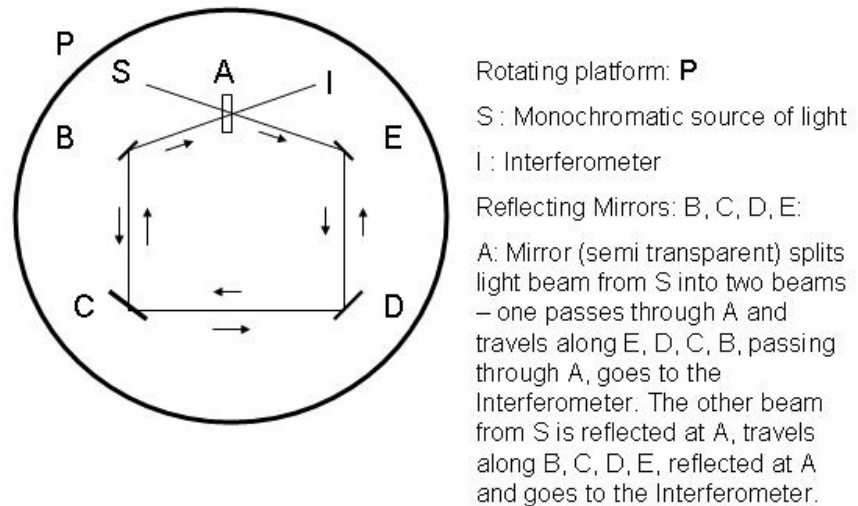

Sagnac experiment

Fig. 11.3

experiments such that it has instantaneous reflection from a mirror, and also instantaneous interaction with the eye of the observer; as if the wavelength is zero. Due to this misconception, it does not become apparent that a moving mirror reflects light of wavelength different from what it receives; and a moving observer too sees light of wavelength different from what he sees the same light to be, when stationary.

In STR, the moving frame of reference (with respect to the stationary one), and the reflecting mirror too, located at the X- axis, should be moving at uniform velocity like the observer. A ray of light from the origin of the axes towards the +X axis in this frame of reference will be reflected by the moving mirror at an *increased* wavelength as shown above. And the observer, because of his motion opposite to the reflected ray, will find the wavelength of this light *decreased* to the original value. In the stationary frame of reference, the stationary observer receives the reflected ray of the same wavelength as that of the ongoing ray. Thus, the observers in both the reference frames find the reflected ray having the same wavelength. Since their time is the same as the universal time, the nos. of shells per unit time, that is the frequency of the light ray, will be equal for both of them; hence, they get the same velocity of light irrespective of the motion of the moving observer.

Fresnel, around 1820, postulated ether-drag in a moving material medium and increase in light velocity on account of this. His ether-drag is close to the velocity-field that gets associated with the moving molecules of matter—responsible for momentum. Transmission of light along the motion of the medium will increase the wavelength, whereas, it's opposite direction will decrease it. As the respective frequencies will proportionality change, the velocity of light in both the directions of light will remain the same. This subtle aspect that despite the changes in wavelengths, the speed of light will be the same does not seem to have been taken note of. In Fizeau's experiment, to measure the speed of light in flowing water, changes in the speed were detected because the conclusion was based on noticing the fringe-shift, which, as explained above, is due to the changes in the wavelengths, and not due to different speeds of light.

If space is assumed to be a void, the speed of light has no medium to be referred to. In fact in a medium of nothingness, neither fields nor light can exist. Therefore, if the velocity of light measured by different observers in uniform relative motion with respect to each other has to be the same as postulated in STR, then, spatial-reality as well as shell nature of light need recognition. With this conceptual shift on the basic nature of the absolute vacuum, and the basic nature of light, the relativistic concepts involving changes in length and time (dependent on the motion of observers) will become redundant.

11.12 Light speed is independent of the motion of the source

Consider an electron with its vortex structure. At any point in space, the velocity field and its radial distance from the vortex center will determine the magnitudes of its gravitational and electrostatic potentials. As discussed earlier, a displacement of the electron's center will produce changes in the potentials. Such changes will occur during the electron's motion, either uniform or accelerating. Equalization of potentials due to self-action of space takes place at speed c with respect to space. Therefore, considering motion of an electron at ordinary velocity, it can be assumed that the field structure of the electron retains its original symmetry of distribution as before (when in a static state).

Let an electron and a positron, moving together at ordinary speed, undergo annihilation. After collapse of the electron's void during annihilation, it loses mass, charge, and its existence. But the light shell produced continues its transmission relative to space with the point of annihilation as its center, independent of the speed of the particles prior to the instant of their annihilation, since the point of annihilation and the surrounding field structure get fixed relative to space subsequent to the annihilation. On similar arguments it will be seen that light produced during atomic vibration is transmitted at speed c relative to space due to self-action of space to equalize the potential gradients. Further, since light shells are massless entities, not emitted from the structure of the electrons (constituting the atoms of the light source), they cannot carry the momentum of the light source.

11.13 Time dilation

The traditional concept of time was revised in STR. Though it has been shown in Sec.11.12 that with the shell nature of light, the postulate of STR on the invariance of the speed of light in different frames of reference is supported, the following thought experiment reveals the fallacy of the often-quoted arguments¹ in support of time dilation.

Fig.11.4 shows a platform in uniform motion with two observers A and B on it, and another stationary observer C on the ground. The relativist's view is that "if the observer A lights a match stick creating a flash, the observer B sitting opposite to him will think that the flash has directly come to him along the route PQ, whereas, the observer C will see the path along PQ¹, since, during the time the flash has reached him, the platform has reached to a new location P¹ Q¹ R¹ S¹. The path of the flash does not look the same to the two observers B and C. Since the flash is *moving with* A, it seems to C taking a longer path; and if the speed of light is to remain the same, the longer path must seem to take longer time: time must pass faster for C". The misconception on the nature of light in the above statement is the presupposition that "the flash is moving with A". But is the flash really moving with the observer A? In Sec.11.12 it was shown that the speed of light is independent of the motion of the source. Hence, the uniform motion of A cannot be imparted to the flash of light that he creates by striking a match. To further pinpoint the relativistic misconception on the motion of the flash along with A, let us suppose that A has with him an electron and a positron that undergo at some instant annihilation. As explained in Sec.11.13 the point of annihilation will get fixed in space, while the observers A and B will move on. Assuming that B can see the point of annihilation even prior to the instant when the light shell consequent to annihilation has reached him, he will see that the point P is shifting to his left due to his own motion on the platform to the right; and by the time B reaches Q¹ he will see that the light shell has taken the route PQ¹ to reach him. PQ¹ is the same length which is seen by C. Therefore, the assumption of the relativist that the flash of light is *moving with* A is erroneous. Further, if the stationary observer C stands at D, where PQ¹ = PD, the light shell will reach both B and C at the same instant. The new concepts of "time dilation" and "simultaneity" are clearly superfluous in STR, since invariance of the speed of light in different frames of reference in relative uniform motion follows otherwise from the very basic nature of light.

¹ The Clock Paradox, Dr. J. Bronowski, Scientific American, February 1963, Vol. 208, No.2. pp. 134-144

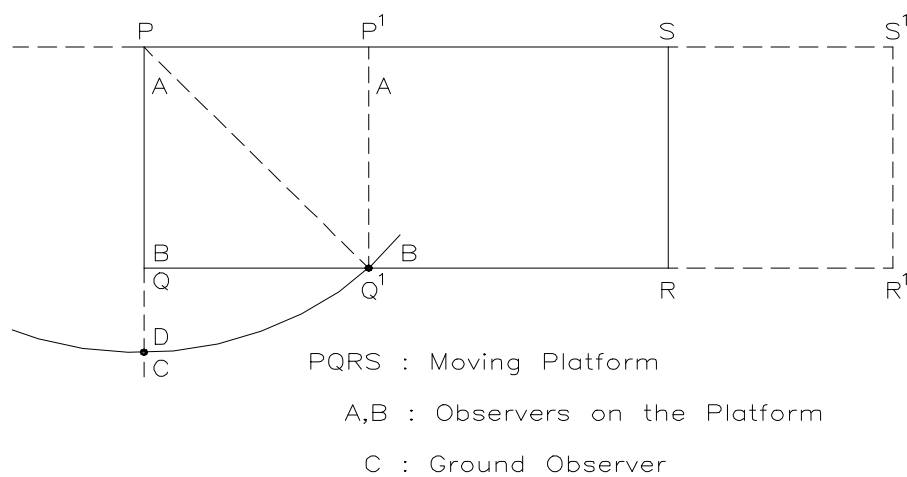
**Fig. 11.4**

Chapter 12

UNIVERSAL CONSTANTS

12.0 Speed of light and electron radius

Presently, Gravitational constant, speed of light, Planck's constant, and the elementary charge, are considered, the fundamental constants in physics. In addition, mass of the electron, dielectric constant and the permeability constant of the vacuum have also been found to be the fundamental constants in SVT. Planck's constant, which plays the central role in quantum physics, has been shown (Chapters 5.1, 5.2) to be a *derived* quantity – one applicable to the electron, and the other to the atoms. Planck's constant for the electron is proportional to c , r_e and m_e . The mass and the charge of electron (4.6, 4.4) have been expressed in terms of c and r_e in mass and charge equations—most fundamental relationships – not yet found in contemporary physics. The dielectric constant for the vacuum (4.24), the permeability constant of vacuum (4.25) and the gravitational constant (Chapter 5.1) are shown to be inversely proportional to c .

The Planck constant, as a derived quantity, has serious implications on the applicability of Heisenberg uncertainty principle and, consequently, on the very foundations of the quantum theory, in which h has been used as a fundamental constant. Derivation of Planck's constant will lead to the revival of “deterministic” approach, presently abandoned by quantum mechanics. Further, as stated above, since “mass” and “charge” have been derived with the use of the universal constants c , and, r_e , the mystery as to why the electron's charge and mass have certain definite values, stands explained. The modern physics recognizes all the above constants *independent of each other* because of the obscurity on their origins and, hence, their interrelationship remains unexplained.

12.1 Fine structure constant

There is also a dimension-less number —“fine structure constant”, expressed as

$$\alpha = q_e^2 / 2 \epsilon_0 h c \approx 1 / 137. \quad (12.1)$$

This dimension-less constant is presently considered to be central to the theory of quantum electrodynamics. Expressing the constants in (12.1) in terms of c and r_e , as per the fundamental definitions to these constants given earlier in this work,

$$\alpha = [(\pi/4) (4\pi r_e^2 c)]^2 / 2 (\pi/2c) (4/5) (4\pi/3) r_e^3 c c r_e c = (15/16) \pi^2 \approx \pi^2. \quad (12.2)$$

From (12.2) it is seen that the “fine structure constant” reduces approximately to π^2 rather than 137, showing, thereby, that there is no special significance of the number 137, except that it could be a cumulative experimental errors in experimental determination of various constants in (12.1).

12.2 Lande g-Factor

Lande g-factor (quantum mechanics) is a dimensionless- constant which, for a static electron (not in orbit), has a magnitude of two. It is expressed as

$$\mu = -g (q_e / 2 m_e) j. \quad (12.3)$$

In (12.3), μ and j are the magnetic moment and the angular momentum of a static electron due to its charge and intrinsic spin. Substituting the values of j from (4.15), and μ from (4.16), in (12.3)

$$g = (3/4) q_e c r_e / (4/5) m_e c r_e (q_e / 2 m_e) = 1.875. \quad (12.4)$$

It's the coefficients in the expressions of charge equation, magnetic moment and intrinsic angular momentum of electron that determine the numerical 1.875. Any other special meaning of the number, 2, to be the value for this constant is most unlikely as per SVT.

12.4 Universality of limiting angular velocity of space

The limiting angular velocity of space, ω , as the ratio of the speed of light c , and the radius r_e of the central void in electron structure, is the universal constant of the underlying universal substratum that unifies all other fundamental constants as explained above. In physical terms it can be stated that the limiting velocity gradient (ω) in the nonmaterial fluid space when the same is in circulation, and the transmission of fields and potentials at constant speed (c) relative to it, are the only two absolute properties that the universe possesses. *Though, the universality of the speed of light is recognized, classically, as the speed of transmission of light with respect to the absolute vacuum; a limit to the flow of absolute vacuum itself at speed of light is the new aspect of SVT.*

Chapter 13

ON CREATION OF COSMIC MATTER

13.0 Expanse of the substantial space of the universe

The universal space could be infinite or finite in its expanse. In the latter case, a sphere of dynamic space can exist in an infinite extension of nothingness beyond its distinct boundary (Fig.13.1), and this leads to the possibility of infinite nos. of spherical universes of substantial space, existent eternally in an end-less void extension beyond our own universe. In a finite universe of dynamic space, the galaxies that are presently observed to be moving away from each other at increasingly higher speeds will retard under the action of their own inward gravity field, or more correctly, their inward free-fall acceleration on their core surfaces, when they reach closer to the universal boundary. A spherical universe will have a center. The galaxies moving away from the universal center will possess spiraling motion due to radial motion of their constituent matter obtained at the time of creation and projection from the universal center (see, next Sec. 13.1) In addition there will be a circular motion of the universal space that constantly interacts with galaxies. Thus, even when the radial motion of the galaxies is reduced to zero, they will still describe circular motion due to a very complex motion that the electrical attractive and repulsive forces among the galaxies might produce. The distribution of galaxies towards the universal center (creative zones) being more than those towards the boundary, the electrical attractive forces may force the galaxies to return towards the universal center in due course. During this motion, as the

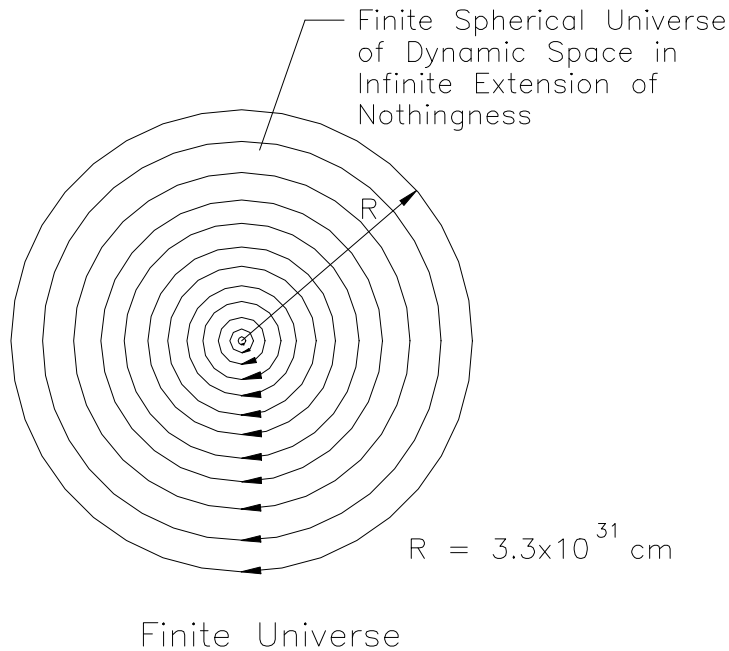
**Fig. 13.1**

distance in between any two galaxies decreases, a reorientation of the directions of the velocity fields in their enclosing vortices may be caused by electrical attractive forces, which will finally lead to their collisions and annihilation of matter in the final stage— annihilation taking place in the basic units of one electron and one positron.

The other possibility of galaxies returning back after reaching close to the universal boundary may be due to an asymmetry of the gravitational fields on the galaxy's surface—the galaxy's core surface, away from the center of the universe, being subjected to a higher density of the gravity fields compared to the inner surface, because beyond the boundary, in the zone of void-ness, fields can not exist.

An estimate on the radius of the finite spherical universe of substantial space can be hypothesized as follows. Since it is an observed fact that the universe has cosmic matter, an electron shot radially out at velocity c from the universal center, retarded by its own inward gravity field, should have zero velocity in close vicinity of the boundary of the universe, lest it loses its existence if it meets the region of void ness at the interface of the substantial-space boundary and the infinite nothingness beyond. Applying the classical law of motion for the radial motion of the electron

$$v^2 = u^2 - 2fs$$

where the symbols have their usual meaning.

Substituting, $u = c$, $v = 0$, $f = (k/4\pi c) m_e / r_e^2$ from (4.27), in the above equation

$$s = c^2 r_e^2 / 2 (k/4\pi c) m_e.$$

Expressing m_e in terms of c and r_e from mass equation (4.6), and $k = s^{-2}$ from (4.27)

$$s = c^2 r_e^2 / (2 s^{-2} / 4\pi c) (4\pi/3) r_e^3 c = (3/2) (c^2 / r_e) s^2. \quad (13.1)$$

Substituting the values for c and r_e

$$s = (3/2) [(3 \times 10^{10} \text{ cm/s})^2 / (4 \times 10^{-11} \text{ cm})] s^2 \approx (3.3) \times 10^{31} \text{ cm}. \quad (13.2)$$

The *minimum* depth of the substantial space of the universe should be 3.3×10^{31} cm. If the universe is assumed to have an infinite expanse of substantial space, the meta-galaxies in it should be far-spaced so as to have negligible electrical and gravitational interaction between them.

Alternately, the radius of the spherical universe can be determined by computing the gravitational potential energy of an electron in the universal space. The difference between the creation energy of the electron (4.14) and its electrostatic energy in space (Section 4.16) resides as gravitational energy, given by

$$E_{\text{grav}} = (4/5) m_e c^2 - (\pi / 10) m_e c^2 \approx (1/2) m_e c^2. \quad (13.3)$$

In Fig.4.6 a, a spherical shell with the constant shell width r_e and of radius r , which gravitationally energizes the universe following void creation, is shown. Since the shell width r_e is much smaller than r , the volume of the shell is taken as: $V = 4\pi r^2 r_e$. To simplify the calculation of gravitational energy due to mass of electron in the universe, we determine the “equivalent mass” of the above volume (if the same is converted into mass by void creation) of the shell from mass equation (4.6):

$$\text{Mass}_{\text{shell}} = (4\pi r^2 r_e) c. \quad (13.4)$$

From (4.27), inward gravity field, $(k/4\pi c) m_e / r^2$, on each point within the shell, acts on the above mass (uniformly distributed in the shell); and work is done in transmitting the shell up to the boundary of the universe. The work done is stored in space as gravitational energy of the electron. Energy required to transmit the shell to a radial length R , where R is the radius of the substantial space of the spherical universe, is the following integral, varying dr from 0 to R ,

$$E_{\text{grav}} = [f M_{\text{shell}} (\text{gravity field in the shell}) dr]$$

$$E_{\text{grav}} = f (4\pi r^2 r_e) c (m_e s^{-2} / 4\pi c r^2) dr = s^{-2} m_e r_e R.$$

$$\text{From (13.3)} \quad (1/2) m_e c^2 = s^{-2} m_e r_e R$$

$$\text{Or} \quad R = (1/2) (c^2 / r_e) s^2, \quad (13.5)$$

which is 3 times less than the universal radius in (13.2). The depth¹ of the universe presently imagined is about 10^{29} cm, which is 330 times less than the radius derived in (13.2).

13.1 Creation of cosmic matter

We can imagine inherent motion in the substantial space of the spherical universe of the radius derived above (Fig.13.1), distributed as “space circulating motion” around the axis through its center, such that the planes at right angles to this axis contain space circulations—their centers coinciding with the axis. This describes the most basic state of the mass-less universe prior to the creation of any matter. The space circulation at the universal center will have to be at speed c to enable creation of cosmic matter. The meta-galaxies and galaxies observed in the universe are, fundamentally, localized space-vortices initially derived from the primordial universal space motion. The nuclei of matter for the formation of galaxies might have been obtained, to start with, from the universal center, where continuous creation of the electrons and their assembly into atoms will take place (due to limiting speed of space circulations) and whirled into outer space at speed of light. In addition to the creation of matter at the universal center, the galaxies will create their own matter, as shown below.

In our galaxy, the solar system exists at a distance of about 2.62×10^{22} cm from the center of the galaxy, revolving around it at speed of 220 km/s. Assuming that similar to the derivation of the velocity fields for the solar space vortex, in the galactic space vortex too, the space-circulation in the diametrical plane at right angles to the axis falls inversely as the square root of the distance from the center of the galaxy

$$v = k_g / \sqrt{r} \quad (13.6)$$

where k_g is a constant and r is the distance from the galactic center. Substituting values of v and r , as given above, in (12.6), we get

$$k_g = v \sqrt{r} = (220 \times 10^5 \text{ cm/s}) \times (2.62 \times 10^{22} \text{ cm})^{1/2} = 3.56 \times 10^{18} \text{ cm}^{3/2}/\text{s}. \quad (13.7)$$

From (13.6) and (13.7), the distance R_g at which the space circulation in the galactic vortex reaches the speed of light is:

$$R_g = [(3.56 \times 10^{18} \text{ cm}^{3/2}/\text{s}) / (3 \times 10^{10} \text{ cm/s})]^2 = 1.408 \times 10^{16} \text{ cm} \quad (13.8)$$

which is about 203000 times more than the solar radius.

¹ The Feynman Lectures on Physics, Volume 1, page 5-9.

Within the central zone of our galaxy, a nearly spherical volume of radius 203000 times the sun's radius is the region of continuation creation of matter starting from the electrons/positrons. With violent motion of these particles at speed of light, the electrons will magnetically attract and electrically repel, thus coming to close ranges, and creating neutrons, protons and hydrogen atoms, projected out from the galaxy's central zone as beams of hydrogen at speeds approaching light speed. The electrons with opposite spins (positrons) will have chance-encounters with electrons leading to annihilation and thus producing gamma radiation. Therefore, it follows, that all those galactic centers, that are pushing-out jets of hydrogen, and are sources of intense gamma radiation, are located in the active region of the universe, continuously creating matter and thereby increasing mass of the galaxies and dispersing matter in the cosmic space for the formation of stars. The creation of matter should be a distinct possibility at the centers of stars as well, as seen further in the analysis pertaining to the Sun.

The mass of matter within the creation zone of the galaxy is found as follows.

The volume of the creation zone, $V_g = (4\pi / 3) R_g^3$; and mass of the galaxy, $M_g = V_g c$, since the entire volume of space in the creation zone circulates at c . Substituting the value of R_g from (9.8), $M_g = (4\pi/3) (1.408 \times 10^{16} \text{cm})^3 (3 \times 10^{10} \text{cm/s}) = 3.5 \times 10^{59} \text{cm}^4/\text{s}$. Converting cm^4/s into gram from (2.12), $M_g = (3.5 \times 10^{59}) \text{g} / 8.6 \times 10^6 = 3.49 \times 10^{52} \text{g}$.

13.2 Creation of matter at the sun's center

For the solar space vortex the constant k was determined (Eq. 6.10) as: $k = 11.52 \times 10^{11} \text{cm}^{3/2}/\text{s}$, and the maximum tangential velocity of space circulation in the equatorial plane was determined as: $V_{sm} = 4.367 \times 10^7 \text{cm/s}$. Consider the case when the Sun had no matter, and the solar space-vortex extended all the way up to its center. From the solar vortex equation (6.7)

$$\sqrt{r} = k / v_t. \quad (13.9)$$

For creation of matter, space-circulation speed should reach c . Substituting the values of k , given above, and $v_t = 3 \times 10^{10} \text{cm/s}$, in (12.9)

$$\sqrt{r} = (11.52 \times 10^{11} \text{cm}^{3/2}/\text{s}) / 3 \times 10^{10} \text{cm/s}.$$

Or,
$$r = 1.475 \times 10^5 \text{cm}. \quad (13.10)$$

In the central zone of the Sun, within a diameter of about 2.95 km the medium of space breaks down, creating continuous matter, starting from the electrons, positrons, and their combinations: hydrogen and other lighter atoms. It is very likely that the created matter, accumulated within the sun over a period of time, leads to intermittent surface-bursts that should account for the observed so-

lar flares. Thus, the stars formed initially from the galactic matter –hydrogen dispersed in space – later create their own matter.

13.3 Creation of matter at centers of larger planets

Part of the gaseous matter at the solar surface is constantly whirled in space by the velocity field of 436.7 km/s (6.11) tangential to the equatorial surface against the inward acceleration field (free fall acceleration) on the Sun (6.12). This matter is also interacted by the velocity field in the solar vortex as it travels in the planetary plane away from the Sun. The planets formation can be supposed to be from the above solar matter. Consider the case of the Earth when its formation began with the solar matter aggregation in space. The tangential velocity of space in the equatorial plane of the Earth in its present formation was calculated as 7.8 km/s with the use of space-vortex equation (6.13) and space vortex constant: $k_e = 1.987 \times 10^7 \text{ m}^{3/2} / \text{s}$. Using this space-vortex equation and the above value of k_e , the radial distance from the center of the Earth's vortex during its initial formative stage, to determine whether the velocity-field had reached speed of light, is calculated:

$$v_m = k_e / \sqrt{r}.$$

Or,

$$r = k_e^2 / v_m^2.$$

Substituting the values for k_e and v_m from above

$$r = (1.987 \times 10^7 \text{ m}^{3/2}/\text{s})^2 / (3 \times 10^8 \text{ m/s})^2 = 0.0044\text{m}.$$

The space circulation at a radial distance of 0.0044m from the Earth's center reaches the limiting velocity, thus leading to the possibility of creation of matter there. Calculations similar to the above indicate that for Jupiter, Saturn and Neptune, radial distances from their centers where the speed of space circulation reaches c , are 1.38m, 0.4m, and 0.74m respectively. It is therefore concluded that the centers of the larger planets possess material creation zones, and this could possibly be the reason for volcanic eruptions on the surfaces of these planets including the Earth.

13.5 Maximum mass of matter in the universe

In Fig.(13.2), the distribution of space circulation in the universe prior to the creation of matter is shown. Considering the plane YZ at right angles to the X-axis, velocity field c at the limiting space circulation creates an electron, which is coaxial with X-axis. From the electron's interface onward the velocity falls inversely as the distance, similar to the velocity variation in an irrotational vortex. All the planes parallel to the Y-Z plane have similar velocity field distribution

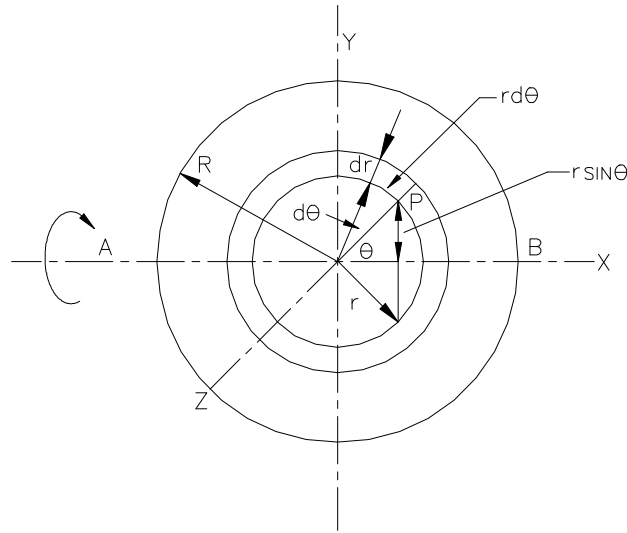

Fig. 13.2

starting with the limiting velocity c on electron interface and dropping off inversely away from the X-axis. Fig.13. 2 shows a spherical shell of the inner radius r . From (2.2), A point P at the shell will have tangential velocity u_p (down the paper) given by

$$\begin{aligned} u_p (r \sin\theta) &= c r_e \\ \text{Or} \quad u_p &= c r_e / r \sin\theta \end{aligned} \quad (13.11)$$

which is the velocity of each point in the shell of infinitesimal radial width dr . The shell consists of several rings in the planes parallel to the Y-Z plane, their axes coinciding with the X-axis. The cross section of the infinitesimal ring shown in the figure is: $(r d\theta) dr$, and the volume is:

$$dV = (2 \pi r \sin \theta) (r d\theta dr). \quad (13.12)$$

All the space points in dV have the velocity field u_p given by (13.11). This volume does not have mass, because there are no voids in it. However, its equivalent mass, that is, the mass produced if the quantity obtained from the velocity-integral of this volume is (mathematically) converted into mass, can be found. The mass-equation (4.6) was derived from the volume-integral of the limiting velocity c . Therefore, equivalent mass of the infinitesimal ring, from (13.11) and (13.12) is

$$dM = dV \times u_p = (2\pi r \sin\theta) (r d\theta dr)(c r_e) / r \sin\theta = (2\pi c / r_e)r d\theta dr. \quad (13.13)$$

The maximum possible mass in the spherical universe is the integral of dM , varying dr from $r = 0$ to $r = R$; and varying θ from 0 to π , which comes to

$$\text{Mass}_{\text{universe}} = (2\pi c r_e) \pi R^2 / 2. \quad (13.14)$$

Substituting the values of R from (13.2), c and r_e

$$\text{Mass}_{\text{universe}} = 1.29 \times 10^{64} \text{ cm}^4/\text{s}$$

which, from (4.12) is

$$\text{Mass}_{\text{universe}} = 1.29 \times 10^{64} (\text{gm} / 8.6 \times 10^6) = 1.5 \times 10^{57} \text{ gm}. \quad (13.15)$$

If we take the farthest depth in the universe, where matter has been presently known to exist, to be the universal radius; and the total amount of matter¹ in the galaxies about $10^{-30} \text{ gm} / \text{cm}^3$, if it were spread evenly all through the space, the estimated mass is

$$\text{Mass}_{\text{universe}} = (4\pi/3) (10^{29})^3 10^{-30} \text{ gm} = 4.18 \times 10^{57} \text{ gm}. \quad (13.16)$$

The theoretically derived maximum possible mass in the universe (13.15), which is created from the dynamic space of the universe, is about 2.7 times less than the presently estimated masses of the galaxies that have been observed. The reason for the calculated mass (13.15) to be less than the estimated (13.16) could be due to the value of the universal radius used for the computation of the mass in the universe (13.16), which is the *minimum* required radius (13.2). The actual radius of the universe, if finite, is perhaps far greater. Indeed, there is no other way but to suppose that the depth of the universal space exceeds $3.3 \times 10^{31} \text{ cm}$.

On the distribution of matter in the universe, refer Fig.13.2. Since matter is created along the axis X and whirled in parallel planes at right angles to the X -axis, the matter dispersed in the planes closer to the axial points A and B will reach and may cross the universe boundary and become non existent; whereas, matter projected in the Y - Z plane and its neighboring regions, unable to reach up to the boundary, will remain existent. Thus, the cosmic matter at the universal scale will have a flat, disc-shaped distribution on either side of the central diametrical plane at right angles to the rotational axis. The distribution of stars in galaxies and the planets in the star systems should also be disc shaped or planes, in general, because of the dispersal of maximum quantity of matter in their respective equatorial planes at right angles to the axes of rotation.

13.5 Limitations of the steady-state and the evolutionary theories

¹ The Steady State Universe, Fred Hoyle; Scientific American, September 1956, Vol. 195, No.3, pp, 157-166

Both the above-mentioned modern theories of cosmology start with the basic supposition of the existence of the most abundant element in the universe—hydrogen. But how was the hydrogen or its component parts—neutron, electron and proton—created? It is the right answer to this question that forces recognition to the spatial reality; not merely in terms of *energy* or *energy fields* created and sustained miraculously in the voidness of space as presupposed today; but rather the recognition of the *space substratum* and its absolute properties that enable creation of fields, energy, as well as matter. The relativity and the quantum theories have not produced a plausible and comprehensible theory of matter, which identifies the fundamental matter and reveals its structure; this aspect is clearly reflected in the following comments¹: “How the protons and neutrons themselves were created is a question outside the province of this article (The Origin of the Elements): only men of strong convictions, religious or scientific, have the courage to deal with the problem of the creation”. As per Hoyle too: “²...the creation of matter may seem a queer concept to be invading scientific thought”. Thus, starting with the hydrogen and its constituent particles (neutron, electron, proton) as *original* matter, these theories exclude from consideration and existence the limiting velocity field necessary for the creation of matter in the universe, and also the circulating velocity field in the medium of space that disperses the electrons and hydrogen atoms away from the creative zones. The evolutionary theory, thus, postulates explosion of an extremely dense neutron core in a primordial “big bang” to explain the apparent expansion of the universe (increasing inter spacing of the galaxies) and the formation of the total quantity of the elements in the universe starting from hydrogen, just in few minutes. It is this matter speeding away due to explosion that built, in due course, the cosmic bodies—galaxies, stars and the planets. “The steady-state hypothesis³ holds that the hydrogen has been created at a steady rate through out infinite time and is still being created at the same rate today, while the higher elements are formed inside stars through nuclear reactions”. But where does the energy for the continuous creation of matter come from? Recourse to relativity theory and Non-Euclidean geometry that the steady state theory takes to explain the above difficulty cannot be considered satisfactory because the dynamic space (Euclidean), which has been shown to be the very basic seat of cosmic energy for the creation and motion of the galactic matter, is neglected by both the prevalent theories. In fact Einstein’s concept that the presence of the cosmic bodies (stars, galaxies) causes *curvature* of the space-time continuum in their neighborhood is a mathematical description that becomes less meaningful, when the basic existence of the circulating non material space around the cosmic bodies is recognized. In this context Dr. Wheeler’s³ comments on my earlier works, *Beyond Matter*, are highly significant. Having quoted in his letter⁴ a line from my above book, “The universe must be dynamic and possess movement” he remarked: “Isn’t this another way of stating the content of Einstein’s 1917 and still standard geometric theory of gravity, according to which the geometry of space is a dynamic entity, changing from instant to instant according to an utterly simple and beautiful law?” Yes, three-dimensional Euclidean geometry is sufficient to ex

¹ The Origin of the Elements. William A. Fowler. Scientific American, September 1956. Vol.195, No.3, pp. 82-89

² The Steady State Universe, Fred Hoyle. Scientific American, September 1956, Vol. 195, No.3, pp. 157-166

³ Dr. J. A. Wheeler, Ashbal Smith Professor and Blumberg Professor of Physics, Center Director, The University of Texas at Austin.

⁴ Dr. Wheeler’s reply (1985) in response to the Author’s letter to him.

plain gravitation and also the source of energy to account for the creation of universal matter, if the existence of the cosmic velocity field or the *dynamic* nature of space is recognized.

13.6 Dark matter

Though, the space vortices enclosing the galactic cores and driving stars in their orbits are the sources for the primordial energy of the universe, yet, these are mistakenly dubbed as dark matter. It is the same dark matter that, as velocity fields around the core of a galaxy, spins it close to the speed of light. It also creates, in our galaxy, the surface gravity of 639.2 m / s^2 – nearly 2.34 times the surface gravity of the Sun (derived earlier in Chapter 6.4.) – thus maintaining stability of the galactic matter, preventing its flying off due to very high-speed rotation of the core.

13.7 Black holes

As described in Section 13.1, galactic centers are the zones of creation of matter due to limiting space circulations. But, the current theories, considering space as nothingness, look for an alternative source of matter to feed black holes. In fact, the central core of any active galaxy spinning at speed close to c is a creation zone. It requires only space circulations at limiting speed to create matter. As the created matter is pushed out due to high speed spin, there will also be inflow of space with ionized matter in the zone. These central creation zones in galaxies are mistaken as black holes.

To postulate that light is gravitationally attracted, so much so, that it can not escape a black hole is the craziest speculation that will amuse the future generations of men of science. For, light being a massless entity, produced due to a time-varying gravitational potential, can not be gravitationally attracted like a body with mass. When light passes in close vicinity of a gravitating body, say, a star, the time-varying gravitational potential that light is, is superposed with the gravitational potential of the star. The result is that the path of the light is seen deflected towards the star.

13.8 Mass Density Limit

The entire mass of the electron has been shown to be due to its void-content (4.6), and not due to the electric charge that it possesses. The concept of “electromagnetic mass” becomes superfluous now that the agencies of mass and charge have been shown to be distinct. Also, since creation of only one stable vortex-structure of electron with least mass and least volume is possible, there comes a maximum limit to the density of mass. Calculated from the ratio of mass of the electron and the volume of the central void in electron structure, this limit comes to $3.42 \times 10^3 \text{ g / cm}^3$. Nuclear radii are presently wrongly considered to be in the range of 10^{-12} cm to 10^{-13} cm , due to which the density of the nuclear mass becomes of the order of 10^{14} g / cm^3 , or even higher. It is also presently estimated that the density of matter in white dwarf is of the order of 1000kg per c.c. However, it can be positively stated that *matter, either in terrestrial or cosmic regions, cannot possess density higher than 3.42 kg per c.c.*

CONCLUSION

The primary reality of the universe is the cosmic energy of space. It exists eternally and is the substratum of the universe. While the process of creation is applicable to matter, it is not relevant to space. The properties of matter are not possessed by the medium of space, which has only one *absolute*-attribute related to the speed of transmission of light in an absolute vacuum. That is, the limiting angular velocity of space-rotation, and the transmission of the effects of potential gradients in it, such as gravitational, magnetic and electromagnetic forces/fields taking place at a constant speed (light speed) relative to it. The Proof of the above postulates has been obtained by deriving *theoretically* all the *basic* universal constants presently known and experimentally determined from the space-vortex structure of the electron. In doing so, the fundamental particle of matter has been identified. It has also been shown that light-speed relative to space is the common factor in all the basic constants. The Newtonian space of void-ness, conceived earlier by Leucippus and Democritus, is shown to be a misconception, whereas the Cartesian space is proved to be closer to the primary reality of the universe.

The process of creation of matter in the universe is the basic phenomenon that converts space-motion of large cosmic space-vortices into submicroscopic space-vortices, created as fundamental particles structured with the highest speed of space-circulation. In this phenomenon of creation, the space-energy from the electron-center is transferred to the universal space as energy fields – gravitational, electrostatic, magnetic, and electromagnetic.

Motion of the fluid-space is the most fundamental velocity-field from which all the above energy fields are derived, i.e. the basic velocity field unifies all the known energy fields. This vindicates the earlier concept of *vis viva* (Leibniz and others) and the 19th century concept of the underlying single force¹: “Between 1837 and 1844, C.F.Mohr, William Grove, Faraday, and Liebig all described the world of phenomena as manifesting but a single ‘force’, one which could appear in electrical, thermal, dynamical, and many other forms, but which could never, in all its transformations, be created or destroyed. That so-called force is the one known to later scientists as energy.”

Due to the existence of velocity fields in the whole universe as large cosmic-vortices with independent centers, cosmic energy resides at each point of the universal space except at the centers of the fundamental particles of matter. This new concept is diametrically opposed to the modern understanding on the seat of energy in the medium of space and in the structure of matter. In the absence of matter and its associated gravity and electromagnetic fields, space is considered *energy-less* according to contemporary physics; whereas, the reality, is that the

¹ The Essential Tension (Energy Conservation), Thomas S. Kuhn, The University of Chicago Press, Chicago and London.

dynamic space is the *first source*, and the *cause* of creation, stability, and the subsequent existence of cosmic matter and fields.

The possibility exists for infinite universes, each a finite spherical dynamic-space of almost endless expanse (Fig. 13.1) existent in the infinite extension of nothingness. The other possibility is of a single universe of dynamic space and of infinite expanse. The creation and annihilation of universal matter is of a cyclic nature, repeating endlessly. Time is inherent in space-motion, but for which, the universe, if imagined to be of static space, is time-less.

The speed of light, when analyzed across a single wavelength by different observers in relative uniform motion, can be shown to be a constant quantity relative to the medium of space, without resorting to the “time dilation”, or “length contraction” as introduced by special relativity theory. Certain experimental setups (Sagnac’s Experiment), meant to determine light’s velocity, use mirrors to reflect a ray or a pencil of light. In the case that these mirrors move relative to space, the wavelength of the reflected light will undergo change. However, this aspect is not taken note of, with the result that the interpretation of the experimental results becomes erroneous.

The velocity fields in the space vortices enclosing the cosmic bodies account for the inward free-fall acceleration (presently taken to be the same as gravitational acceleration) on their surfaces. This acceleration field also interacts with the acceleration field in the wavelengths of the star-light as it passes close to a cosmic body (star), thereby deflecting the same. The modern supposition, that stars attract light *gravitationally* because light possesses mass, is erroneous.

The conclusion of modern theories, as stated every now and then, that absolute space, time, simultaneity, and space filling media are discredited ideas, is certainly premature, unless it can be proved distinctly through these theories that space, as a real entity, plays no part in the structure of fields and matter.

There is uniformity in the structural design of matter, right from the fundamental particle to the largest cosmic bodies, galaxies and meta-galaxies. For instance, the electron has a void-center enclosed within a space vortex; and the atom has an assembly of electrons and positrons (multiple single voids) as its nucleus, with an overall space vortex; the Earth has an assembly of atoms (with void content) enclosed within a space vortex that carries the Moon; the Sun too is made up of atoms, with void-content and an overall space vortex which through the velocity fields of its vortex rotates the planets in the planetary plane. The galaxies also are enclosed within space vortices that carry stars around their respective centers. Therefore, micro and macrocosmic correspondence is a basic fact followed by nature, although currently denied by contemporary physics.

As repeated several times before, modern theories of atomic structure have not so far discovered that the electron is the *fundamental* particle. The presence of electron bound in the nucleus was discarded by quantum-mechanical analysis (quantum theory) despite the experimental evidence of electron emission in nuclear decay. Collision of high energy particles in particle-accelerators results in the creation of high velocity fields (motion of space motion, approaching light speed), associated with the kinetic energy of the colliding particles that give rise

to numerous unstable particles. This is considered astonishing because the creative process of stable particles from the dynamic and substantial space is far from the grasp of the modern principles of physics. The appearance of short-lived particles in high-energy collisions is no proof that all of these particles emerge from the structure of the colliding particles and can form the stable nuclei of atoms. Quarks are not the constituents of nucleons as shown by SVT. All elements, including the radioactive ones; in fact, all matter in the universe has only the electron as the stable basic building block. The concept of anti-matter, again, is untenable. It is only a matter of the direction of the spinning space –as seen in the structure of the electron that makes it a particle (electron) or an antiparticle (positron).

On the basic source of charge of the electron, contemporary theories have reached an impasse. It was pointed out by Salam: “If the electron is indeed a charged sphere [and this presumption, in his words, enables one to account for the mass and dimensions of the electron –Pakhomov], why does it not explode on account of the electrostatic repulsion of various parts of it?”¹ The space vortex structure of the electron, which is shown to be stable dynamically, does not present such problems.

The problem with modern nuclear physics is that the *inward* force on the nucleus, in opposition to the Coulomb repulsive forces within the nucleus, remains undetected due to the assumed void-ness around the nucleus. The atomic vortex which creates the inward force on the nucleus, the electric charge of the nucleus that binds which carries the orbital electrons around, has been ignored, with the result that atomic theories are based on ad hoc hypotheses leading to some grave misconceptions. For example: Bohr’s atom had allowed/disallowed orbits of electrons and different *energy states*. An electron, *jumping* from one orbit to the next *emits* energy in the form of light; the electrical repulsive force between two electrons is explained by the exchange of *virtual* photons; electromagnetic attraction between the nucleus and the electrons in the orbits is also believed to be due to the exchange of *virtual* photons; interactions between particles are explained through *force-carrying* particles. Clearly, all these are not facts but fallacies as shown by the principles of SVT.

There is also a serious misconception that particles and also the electron can *absorb* and *emit* energy. The electron can gain or lose only kinetic energy in collision with other particles, or, when accelerated by electric or magnetic fields. The electron has no energy at its center from which to emit a photon. Neither can any particle penetrate the highest velocity field which forms the interface of the electron with the substratum of space, except when it comes in contact with a positron resulting in its annihilation when velocity fields of opposite directions are superposed.

The release of radiation energy from an orbital electron in the atom at a frequency proportional to the rotation of the electron in its orbit, when the same jumps to an orbit closer to center, is not the actual process of production of light. It is mistakenly accepted that the basic source of light is from the orbital elec

¹ A. Salam, “Elementary particles” (Contemporary Physics 1, No. 5, 343-44, 1960)

trons. As explained earlier, oscillating atoms, only *initiate* formation of light shells in their immediate vicinity. These light-shells are further transmitted and *produced* by their time-varying gravitational potential, which is already existent at each point in space. Also, an orbital electron carried ceaselessly by the non-viscous space vortex of the atom, does not lose its kinetic energy due to circular rotation. So the very question of its *losing* energy and falling towards the nucleus is hypothetical. Bohr had to postulate fixed orbits for the orbital electron in the atom because of the above misunderstanding originated from classical physics.

It is not accepted in today's physics that Planck's constant can be derived from the time-varying gravitational potential of a *neutral* atom, without taking into account the electric charge of the orbital electrons. The concept in classical physics has been that only an *electrically charged* oscillator can produce electromagnetic waves. Plank derived this constant from thermal radiation, and as such, only its relationship with heat and light has been proven. Under the concept that all the light from an oscillating atom is produced from the *charged* orbital electrons, the best guess for the theorists in the past, would have been to assume that the angular momentum of the orbital electron should be equated with the Planck's constant because both have the same dimensions and are even numerically quite close. To satisfy the compulsion to obtain an *indivisible* quantum of energy in one photon, the angular momentum was quantized. The next step in this speculative process was to assume the frequency ω of the angular rotation of the electron in its orbit to be the frequency of the light emitted by it. This was, clearly, a wrong step, because to-and-fro motion of the electron (Fig. 5.2), is an accelerating motion that will produce light shells, whereas, orbital electrons have uniform circular motion, and will not produce light. Moreover, basic function of the orbital electrons is to neutralize the nuclear charge through their intrinsic and angular momenta (Section 4.21)..

It followed from relativity theory that all types of energy, have mass associated with it. It is true that energy has its equivalent mass *mathematically*, but creation of mass requires fulfillment of certain rigid conditions, as shown in the process of the electron's creation. Since creational requirements were not known and not dealt with even in modern theories, photons were assigned mass and wavelength and momentum, through mathematical treatment without identifying accompanying physical aspects. Compton's effect used billiard ball like collision between an electron and X-rays because photon was assumed (wrongly) to have momentum like a particle. Further, photon was supposed to have a large amount of an indivisible energy quantum, hf , without any storage mechanism (a concept used in describing photoelectric effect by a physically impossible process of concentrating energy at a point in the wavefront of not only one shell of light but also pertaining to f nos. of shells emitted in unit time), which it transmitted partly to the electron instantaneously when they collide. Even if it is granted that the photon has a storage mechanism, it would take *one second* to accumulate energy of quantity hf , how could it then transmit this quantum of energy *instantly* in its

random collision with the electron? And worst of all, as previously, the kinetic energy that the ejected electron would have had in its atomic orbit before release was ignored, in the same way as in photoelectric effect. The observed kinetic energy of the ejected electron was, thus, wrongly conceived to be coming out of the photon. It all started with assigning mass and momentum to the photon and arriving at its wavelength mathematically.

Matter waves were postulated following effect, noted by Compton. Louis de Broglie reasoned that similar to light, which shows wave-particle nature, matter too as a particle would have wave behavior. Here was a postulate that originated and rested on the false premise that photons possess mass and momentum like a particle of matter. In a super fluid¹ space, with nonmaterial properties, vortices of matter (particles, charged or uncharged) moving at high speeds, will naturally create wave-like patterns of velocity field and potentials around the particles. The diffraction of electrons similar to X-ray is on account of reaction to fluid space. Matter waves, in close vicinity of particles in motion relative to space, only prove spatial fluidity and its reality, but are not indications that electron has a wave character. Further ideas on standing matter-waves and quantization of wavelength became the founding principles for wave mechanics, which does not permit physical picture of the electron encircling the nucleus in a circular orbit; rather, the orbital electron is 'spread out' in some unimaginable way.

The uncertainty principle of Werner Heisenberg appears to be the outcome of his pursuing an idea that the atomic structure need not have a physical picture or space-time representation. The *impossibility* of physical representation of wave-particle aspects of light would have been a crucial factor in his avoiding the mechanical details on the orbit of the electrons in the atomic model of Bohr. However, the basic principles on which he proposed the Uncertainty Principle rested on 'matter waves' leading to 'wave particle' duality, preceded by 'photon momentum' and 'photoelectric effect' that brought in the particle concept, with support from the Planck constant. Naturally, the errors pointed out earlier, in the use of these faulty concepts developed within a short time frame of two and a half decades of the 20th century, became cumulative and highly complex in the uncertainty principle, leading to some odd conclusions. For instance, in this principle only those quantities are real that are measurable. Also, the motion of an electron cannot be *described* with unlimited precision. True, who can expect *description* of electron motion to an *unlimited* precision, when little is known of the very structure of the electron? With regard to modern theories, if the medium of space in which the electron moves is presupposed as a void, how would the radius of electron (if it does have a radius) – a submicroscopic entity – be measured through experiments? It can only be derived using experimentally obtained mass and charge, and through the use of new relationships – just as has been done in my work. The precision of description in a theory depends upon the clarity of the

¹ In my first article "The Physical universe", 1974, nonmaterial space was referred as "super fluid". I discontinued its use in my subsequent works since few scientists in India picked up this word and its nonmaterial properties; and published the same with no reference to my work.

physical picture, and the depth to which the analysis has been taken. But the uncertainty principle seems to avoid the unavoidable.

The concept of classical electrodynamics that an accelerating or oscillating electron gives-off energy is based on an implicit understanding that the electron structure is packed with energy all the way up to its center. Such a conclusion is obviously justified under the modern conception of *emptiness* of space and *solidity* (energy content) of matter. However, the existence of the central void in the vortex structure of electron, now proposed through SVT, reverses the entire system. Firstly, it does not provide for any detachment (emission) of light energy from the electron; and secondly, it gives stability preventing dissipation of vortex motion. Thus there is no exchange of energy between an oscillating electron and the light produced by it. The other single entity that became a source of error, starting from the photoelectric effect, in almost all the theories of atomic physics is the *indivisibility* of energy in Planck's quantum. This is because the true physical nature of electron was obscured. Detailed physical aspects may not be revealed by mere mathematical expressions in the form of equations and may not safeguard true nature of reality.

The situation today in our understanding of the fundamental aspects of space and its relation with matter has not had any appreciable change since the early twenties of the 20th century, when Sir Oliver Lodge, in his paper "The Geometrization of Physics", summed up: "In such a system there is no need for Reality; only phenomena can be observed or verified; absolute facts are inaccessible. We have no criterion for truth; all appearances are equally valid; physical explanations are neither forthcoming nor required; there need be no electrical or any other theory of the constitution of matter. Matter is, indeed, a locally constructed illusion generated by local peculiarities of space. It is unnecessary to contemplate a continuous medium as a universal connector, nor need we try to think of it as suffering modification transmitted from point to point from the neighborhood of every particle of gravitational or electrified matter; a cold abstraction like a space-time manifold will do all that is wanted, or at least all that the equations compel.... But notwithstanding any temptation to idolatry, a physicist is bound in the long run to return to his right mind; he must cease to be influenced unduly by superficial appearances, impractical measurements, geometrical devices, and weirdly modes of expression; and must remember that his real aim and object is absolute truth, however difficult of attainment that may be; that his function is to discover rather than to create; and that beneath and above and around all Appearances there exists a universe of full-bodied, concrete, absolute Reality".

The absence of physical explanations for atomic processes has been a crucial missing link in atomic physics. Aristotle's principle of *material* and *efficient* causes was echoed in Descartes' Vortex Theory. Descartes proposed ether for the material cause and "circulation in ether vortex", as the efficient cause, which was used in an attempt to explain mechanical action of gravity. Later, despite the reintroduction of "action at a distance" (Newton), that throws light neither on material nor on the efficient cause, explanations to the effects associated

with heat, electricity, and magnetism, continued to be mechanistic. The physics of the 19th century adopted more mathematical systems in the explanations of physical phenomena. This was followed by Faraday's discovery of continuous field lines and his experiments revealing an underlying unity in space. And Maxwell's assumption of fluid-ether, led to the formulation of his equations. Yet, physics of the time, took this to mean, that the concept of mechanical-ether cannot derive electro-dynamics equations. The import of this development, as taken by the physics of this time, was that the concept of mechanical ether would not allow the derivation of the electrodynamic equations. Such a conclusion, totally neglected the need for the *substance* which constructs a material entity, and the *origin* of the forces in the structure.

It has now been shown that there are relationships for electron mass and charge at a more fundamental level than allowed by Coulomb, Gauss, Ampere's law and Maxwell's equations. With the equations of SVT, not only can Maxwell's equations be derived, but their flaws if any, can be exposed. Even an individual event, like an electron annihilation, production of a light shell, motion of orbital electron, creation of electron, and similar such effects can be explained with deterministic approach using SVT. Will quantum physics, then, continue asserting that physical pictures fall within the domain of philosophy rather than physics?

A conceptual reorientation is needed today. It ought to shift the modern trend of assuming *outward* direction of the forces in material structure to an *inward* direction. It should posit *basic* reality to the medium of space, and matter to be the product of space. It must admit strict adherence to the cause-effect law, and a deterministic approach. These describe the needed course of action today, - so as to incorporate physical aspects in each phenomenon, and thereby achieve reconstruction of the ongoing theories, classical as well as major revisions to Relativity and quantum physics.

Appendix

A 1 Electrostatic Energy in electron vortex

For a stationary electron, the “energy density” in its electrostatic field in the universal space as per classical physics is computed as, $\epsilon_0 E^2 / 2$, where E is the electric field at a distance r from the electron center. With the use of this relation of the energy density, the electrostatic energy in the velocity field of electron vortex is calculated as follows.

The electric field E of electron on an elemental ring of space area, $(2 \pi r \sin \theta) r d\theta$, at a distance r from its center, from (4.18)

$$E = -c^2 r_e^2 \sin^2 \theta / 2 r^2.$$

Energy density at a distance r from the electron center, using (4.24) for the dielectric constant and the above equation

$$\epsilon_0 E^2 / 2 = (\pi / 2c) (c^4 r_e^4 \sin^4 \theta / 4 r^4) / 2 = \pi c^3 r_e^4 \sin^4 \theta / 16 r^4.$$

From the elemental ring area calculated above, the element of space volume is: $2\pi r^2 \sin \theta d\theta dr$. The total electrostatic energy is

$$\begin{aligned} U &= \int_{r_e}^{\infty} \int_0^{\pi} (\pi c^3 r_e^4 \sin^4 \theta / 16 r^4) 2\pi r^2 \sin \theta d\theta dr. \\ &= (16 / 15) (\pi^2 / 8) c^3 r_e^3. = \pi / 10 [(4\pi / 3) r_e^3 c] c^2. \end{aligned}$$

Replacing the quantity in the bracket by m_e

$$U = (\pi / 10) m_e c^2.$$

It is seen in the above integral that the lower limit of r is the void-radius r_e of the electron, rather than zero, as is the case with a point-charge, which will have infinite amount of energy in its electrostatic field when r is taken as zero. The value of r cannot be less than r_e , because the void at the electron center is field-less. *The existing inconsistency of locating energy in the field with the point-charge concept of electron gets removed with the vortex structure of electron.* The elec-

rostatic energy is less than the total electron-creation energy in space. The difference should appear as electron's gravitational energy in space.

A 2 Gauss' Law

Consider a Gaussian surface –a sphere of radius r in space –with an isolated point charge at its center. From symmetry considerations the electric field E is taken normal to the surface, and has the same magnitude at each point on it. As per Gauss' Law, the electric flux (Φ_E) and the charge q inside are connected as

$$\epsilon_0 \Phi_E = q$$

or
$$\Phi_E = q / \epsilon_0$$

and
$$\epsilon_0 E (4\pi r^2) = q.$$

In the case of the electron's space vortex structure, the spherical interface of radius r_e replaces the Gaussian spherical surface. The electric field, starting from the interface, has axial symmetry. For calculating the electric flux on the interface, consider (Fig. 4.2) an element of area $dA = 2\pi r_e \sin\theta r_e d\theta$, which has at each point the electric field given by (4.18). Substituting, $r_e = r$, and varying θ from 0 to π , the electric flux is given by

$$\Phi_E = \int_0^\pi (-c^2 \sin^2\theta/2) 2\pi r_e^2 \sin\theta d\theta = (4\pi/3) c^2 r_e^2 = -2/3 (\pi/4 \cdot 4\pi r_e^2 c) 2c/\pi.$$

Replacing the quantity in the bracket by q_e , and substituting $1/\epsilon_0$ for $2c/\pi$, as derived in (4.24), we have,

$$\Phi_E = (-2/3) q_e / \epsilon_0,$$

which is Gauss' Law except for the factor $(-2/3)$, which appears due to the fact that the electric field of the electron is axisymmetric.

A 3 Table 1

Some Dynamical Characteristics of Solar System

	Earth	Mars	Jupiter	Saturn	Neptune	Uranus	Pluto	Sun
Space-circulation around the planet, v_s , (km / s)	7.8	3.72	41.8	24.9	16.5	15.18		436.7
Orbital velocity (km /s)	29.8	24.1	13.1	9.64	5.43	6.81		
Resultant velocity, v_o (km / s)	37.6	27.82	54.9	34.54	21.93	21.99		
Radius (km)	6400	3395	71500	60000	24750	25900	1700	6.96×10^5
$v_s R^{1/2} = k$ ($m^{3/2}/s$)	1.987×10^7	6.8×10^6	3.53×10^8	1.93×10^8	8.2×10^7	7.7×10^7		11.52×10^9
Free-fall Acceleration v_s^2 / R (m / s^2)	9.55 (9.78)	4.07 (3.72)	24.5 (22.9)	10.4 (9.05)	11.02 (11.0)	8.9 (7.77)		274 (274)
Surface tangential velocity (km / s)	0.466	0.239	12.7	10.23	2.73	0.16	0.013	1.945
Electrical charge on surface (CGSE)	1.85×10^{23}	2.72×10^{22}	6.4×10^{26}	3.63×10^{26}	1.648×10^{25}	1.05×10^{24}	5.5×10^{20}	0.928×10^{28}
Mass (kg)	2.25×10^{24}	4.71×10^{23}	8.34×10^{26}	6.47×10^{26}	2.3×10^{25}	2.4×10^{25}	1.26×10^{22}	

Note: The ratios of the mass of the planets with the new mass of the Earth are: Mars – 0.19 (0.107); Jupiter-337 (318); Saturn-261 (95.1); Neptune-9.3 (17.2); Uranus-9.7 (14.5); Pluto-0.005 (0.002), where the figures within brackets are the presently accepted values

A 4 Table 2

	Earth	Mars	Jupi- ter	Saturn	Ura- nus	Nep- tune	Sun
Volume, V, (cm ³)	1.08x1 0 ²⁷	1.64x1 0 ²⁶	1.53x1 0 ³⁰	9.04x1 0 ²⁹	7.27x1 0 ²⁸	6.34x1 0 ²⁸	1.41x1 0 ³³
V _s , (cm/s)	7.8x10 ⁵	3.718x 10 ⁵	41.8x1 0 ⁵	24.9x1 0 ⁵	15.18x 10 ⁵	16.5x1 0 ⁵	436.7x 10 ⁵
Orbital ve- locity, v (cm/s)	29.8x1 0 ⁵	24.1x1 0 ⁵	13.1x1 0 ⁵	9.64x1 0 ⁵	6.81x1 0 ⁵	5.43x1 0 ⁵	zero
(V _s + v), (cm/s)	37.6x1 0 ⁵	21.81x 10 ⁵	54.9x1 0 ⁵	34.54x 10 ⁵	21.99x 10 ⁵	21.93x 10 ⁵	436.7x 10 ⁵
Mass= V(V _s +v)/8.6 x10 ⁶ (gram)	4.72x1 0 ²⁶	4.15x1 0 ²⁵	9.76x1 0 ²⁹	3.63x1 0 ²⁹	1.86x1 0 ²⁸	1.62x1 0 ²⁸	7.16x1 0 ³³

gram = 8.6×10^6 (cm⁴/s)

V_s = Maximum velocity field in the space-vortex

v = orbital velocity of a planet is equal to the velocity-field of the solar space-vortex at the orbit

A 5 Author's Works

1. The Physical Universe (1974); The Substantial Space and Void nature of Elementary Material Particles (1977); Space Vortices of Energy and Matter (1978); The Origin of Electron's Mass, Charge, Gravitational and Electromagnetic Field from Empty Space (1982); Beyond Matter (1984): Private Publications.
2. Space is the Absolute Reality (1982), Proceedings of ICSTA, International Publishers, East-West, Niederschocklstr, 62, 8044 Graz, Austria.
3. Beyond Matter -A Comprehensive Theory of the Material Universe (1995), Editor: Wolfram Bahmann, Feyermuhler Str. 12, D-53894 Mechernich
4. Physics of Space Power Generation (1996); Universal Principles of Space and Matter –A Call for Conceptual Reorientation (2002); Crest Publishing House, G-2, 16 Ansari Road, Darya Ganj, New Delhi-110002.

5. Articles published in International Conferences: The German Association of Gravity Field Energy (1987); Foundation of Mathematics and Physics, 1989; International Symposium on New Energy, USA, 1993, 1994; Congresso Interzionale, Perugia, Italy, 1996; Galileo back in Italy, International Conference, Italy, 1999; Internatuonal Conference (Psychotronics), Japan, 1996.
6. On Planetary Motion caused by Solar Space Vortex, 1998; Conceptual Error on the Fundamental Nature of Light-phenomenon in Classical Electrodynamics, led to the Complexities in Quantum Physics (1998); Creation of Galactic Matter, and Dynamics of Cosmic Bodies through Spatial velocity Fields (1999): Journal of New Energy, 3084 E. 3300 South, Salt Lake City, Utah 84109-2154

About the Author

Paramahansa Tewari (born 1937), B.Sc. Engg, is the Former Executive Director (Nuclear projects), Nuclear Power Corporation, India. After a rigorous study of the foundations and basics of physics and the accepted laws of physics, he discovered new equations defining matter and the mass and charge of the electron. The main aspect of his Space Vortex Theory, which was first hypothesised in mid 1970s, relating to the unexplained phenomena of physics, include the creation of the electron and gravitational, electrostatic, and electromagnetic energy fields, the discovery of a fundamental state of cosmic energy (the fundamental particle of matter); and the creation and stability of universal matter. He has lectured internationally on the principles of his new theory.

About the book

Abstracts from the letters of Dr. John Archibald Wheeler and Dr. Abdus Salam – given at the back cover of my book “Universal Principles of Space and Matter” –may be placed.

